

. EST 1956 .

CARASEL

TOWBARS

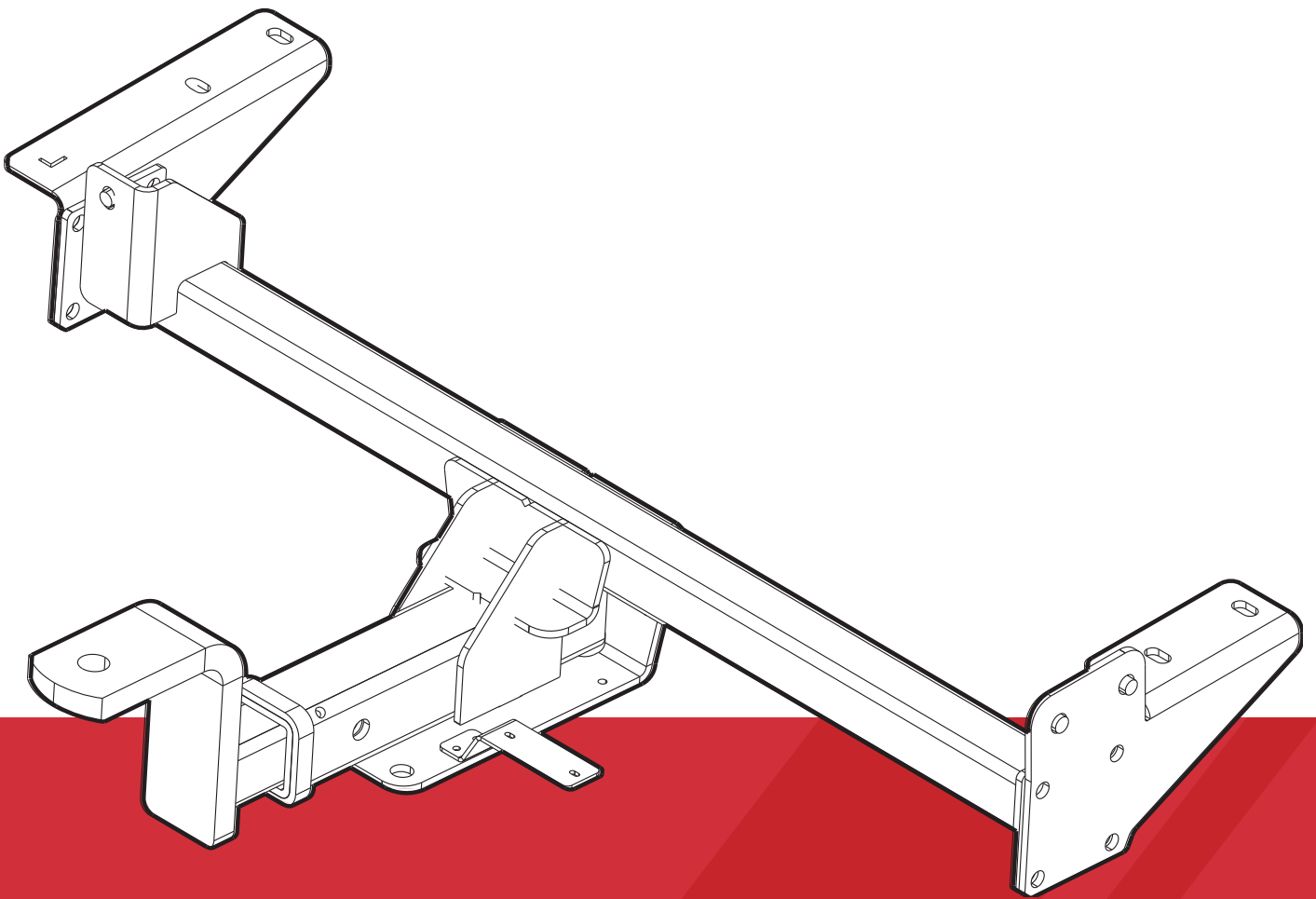

NISSAN LEAF
P/N - NI1G2



LIFETIME
WARRANTY

Issue02

PARTS LIST

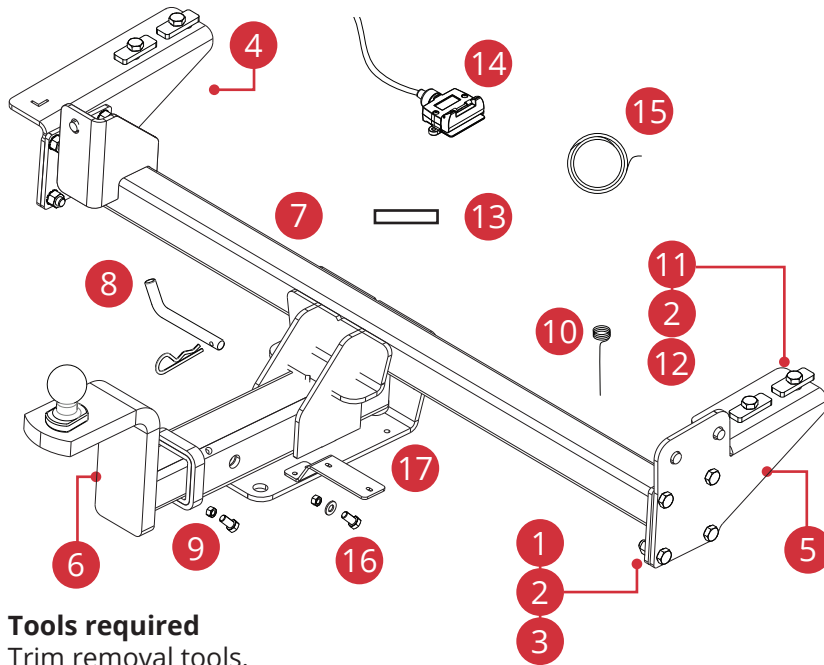

PN	DESCRIPTION
1	3/8" x 1 HEX SCREW
2	TOOTHED WASHER
3	HEX NUT
4	VERTICAL BRACKET LEFT
5	VERTICAL BRACKET RIGHT
6	TOWBAR HITCH
7	CENTRE FRAMEWORK
8	PIN & R-CLIP
9	RATTLE BOLT
10	SPRING FISH WIRE TOOL
11	3/8" x 1.25 BOLT
12	PLATE WASHER
13	LOAD RATING LABEL
14	7 PIN TAIL
15	TRACE WIRE
16	M5 BOLT, WASHER & NUT
17	PLUG PLATE

Tools required

Trim removal tools.
Socket wrench and set.
Cutter.

IMPORTANT INFORMATION

This product is for towing purposes only and must only be loaded as shown in your vehicle Owner's Manual.

- This towbar is NOT to be drilled, cut, welded, or modified in any way.
- Check behind chassis rail and body panels before drilling to ensure no hazards are present.
- All load ratings shown are under the assumption your trailer has a functional braking system installed.
- When installed in positions other than the one depicted in these instructions the Tow Ball Mount may interfere or obstruct certain features of your vehicle. (tailgate opening, Chassis clearance, etc.)

General:

- Read fitting instructions and check installation hardware is correct.
- Check that the towbar is suitable for the vehicle and be wary of any changes to the vehicle design that may conflict with the fitting of this towbar. (Tray, Canopy, Suspension etc.)
- After drilling, blow any filings clear, remove any swarf and treat exposed metal with a rust inhibitor.

Towbar Maintenance and Care:

- It is recommended, when not in use, the towball mount assembly and CLASS 4 Pin and Clip is stored inside the car away from moisture to prevent standing water from forming rust.
- Inspect to ensure, on regular basis, fasteners are torqued to the specifications below and in good condition.
- Ensure that the fitting instructions are read and understood prior to fitment.
- Place these instructions in the vehicle's glovebox after installation is completed.

STEP 1

Remove rear lower plastic panel. Hardware around the plastic panel must be stored for reassembly.

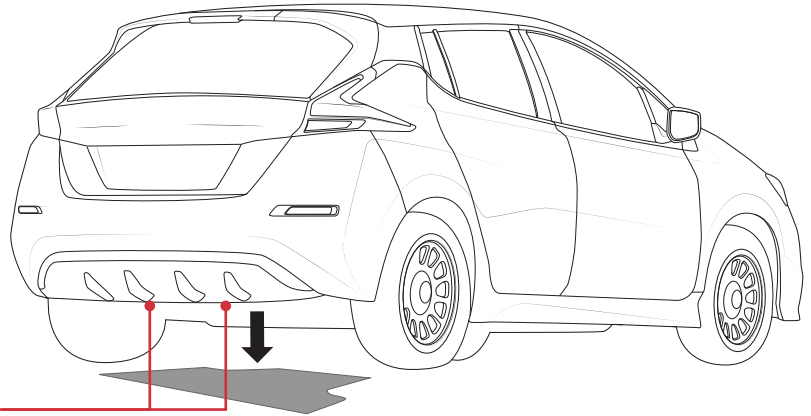
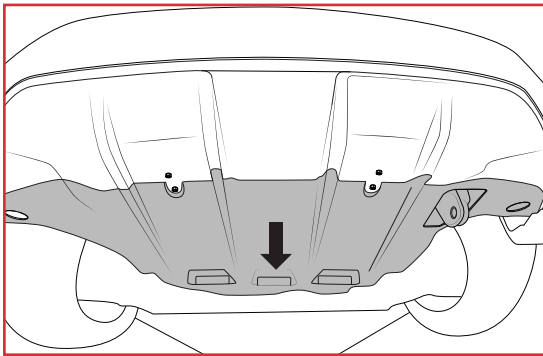

STEP 2

Remove the tow hook from the drivers side of the vehicle.
DO NOT DISCARD

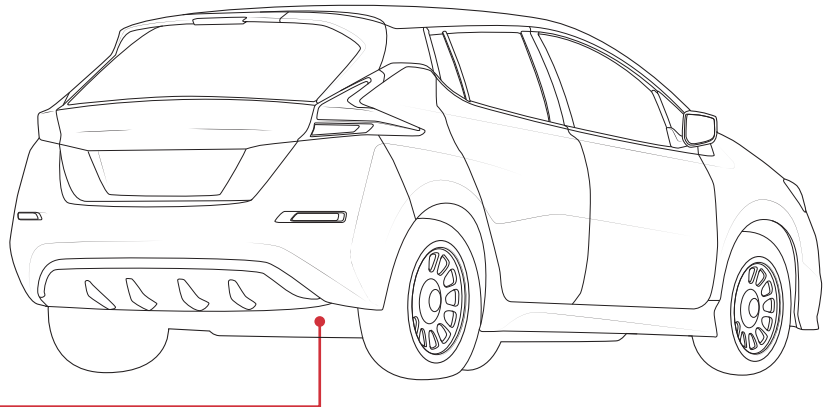
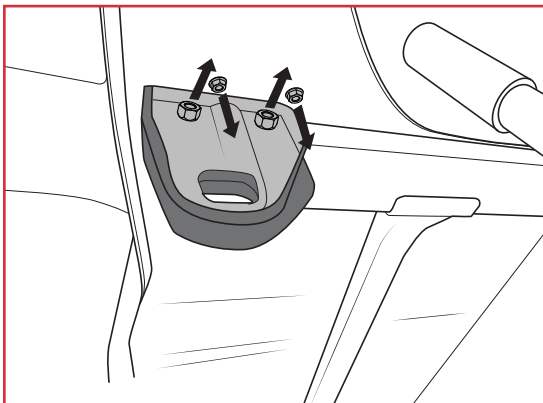

STEP 3

Slide a plate washer, lock washer and then wind on 3/8" x 1.25 bolt at least 4-5 full revolutions, onto the spring fish wire tool.

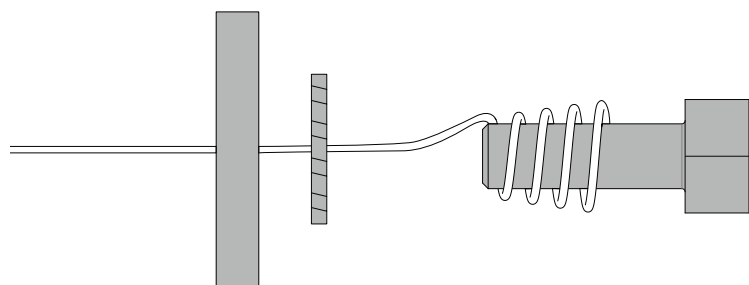

STEP 4

Feed the Spring fish wire tools into the holes in the chassis, near the rear wheel as shown.

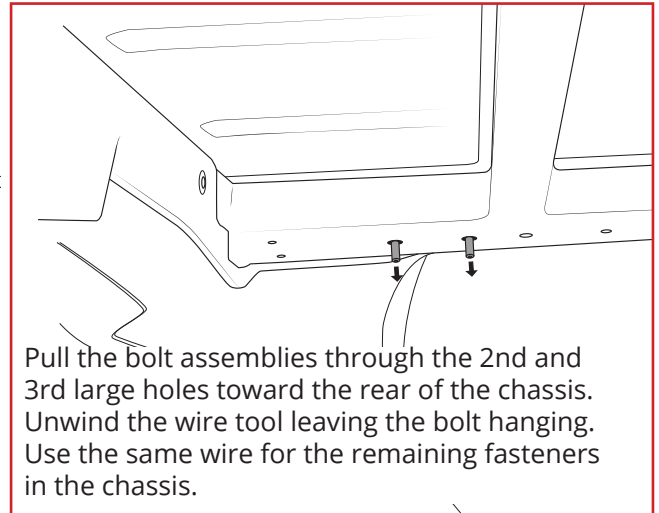
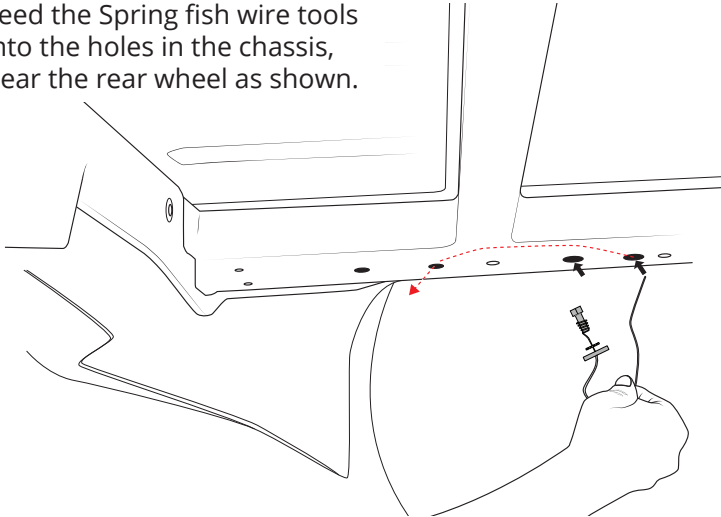

Pull the bolt assemblies through the 2nd and 3rd large holes toward the rear of the chassis. Unwind the wire tool leaving the bolt hanging. Use the same wire for the remaining fasteners in the chassis.

STEP 5

Position the hitch brackets carefully over the bolts installed through the chassis. **Be careful not to push the bolts back into the chassis.**

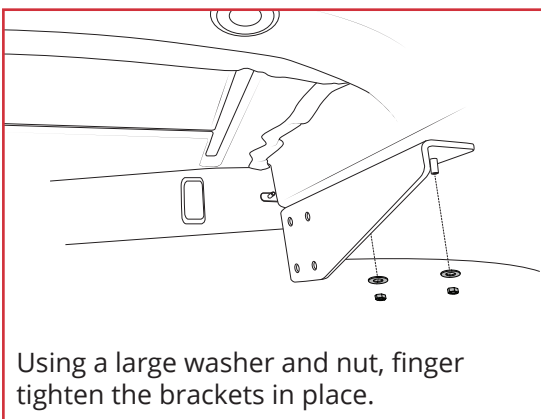
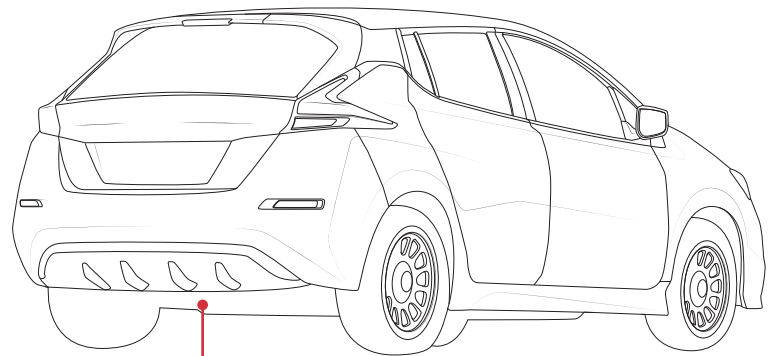
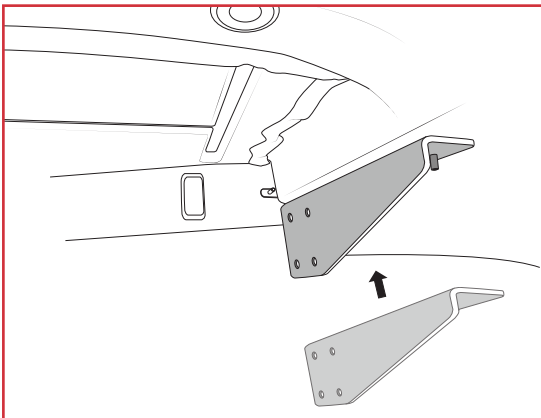

Using a large washer and nut, finger tighten the brackets in place.

Re-fit the side bolts washers and nuts on the drivers side that were removed from the Tow hook.

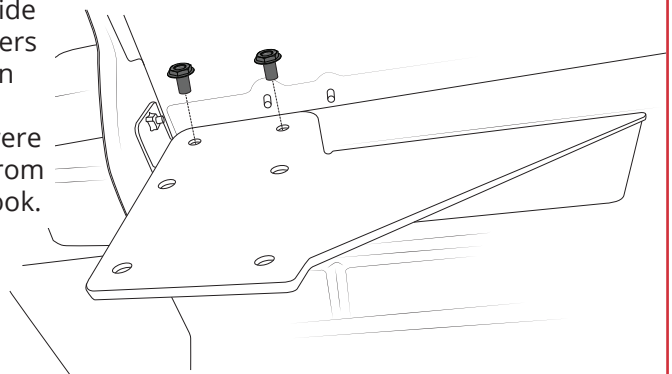

STEP 6

Lift up main cross beam and fit 8 x 3/8" x 1 bolts with lock washers and nuts. All bolts are only finger tight at this stage.

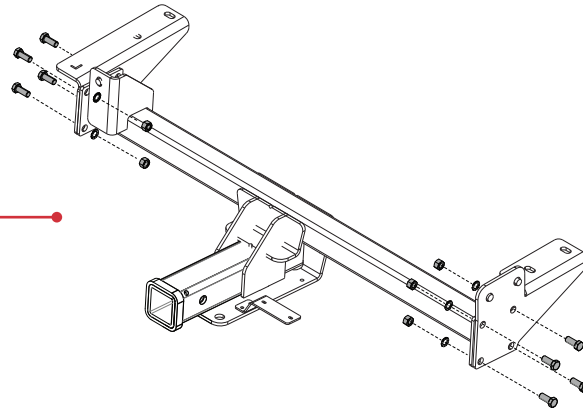

Then with the assembly in place, tighten all hardware.

STEP 7

Fit hardware through the crossbeam point to the hole in the vehicle as shown. Fix in place.

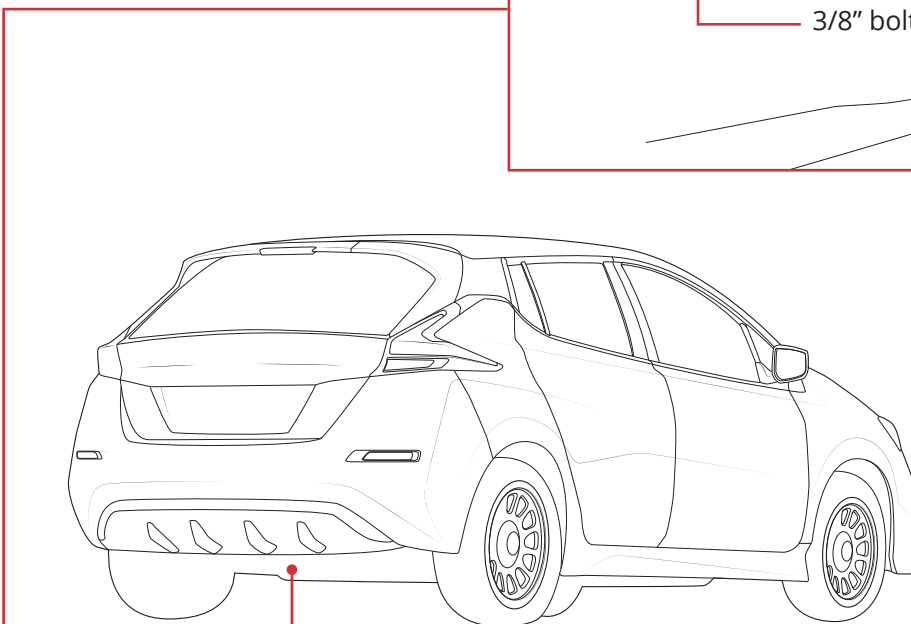
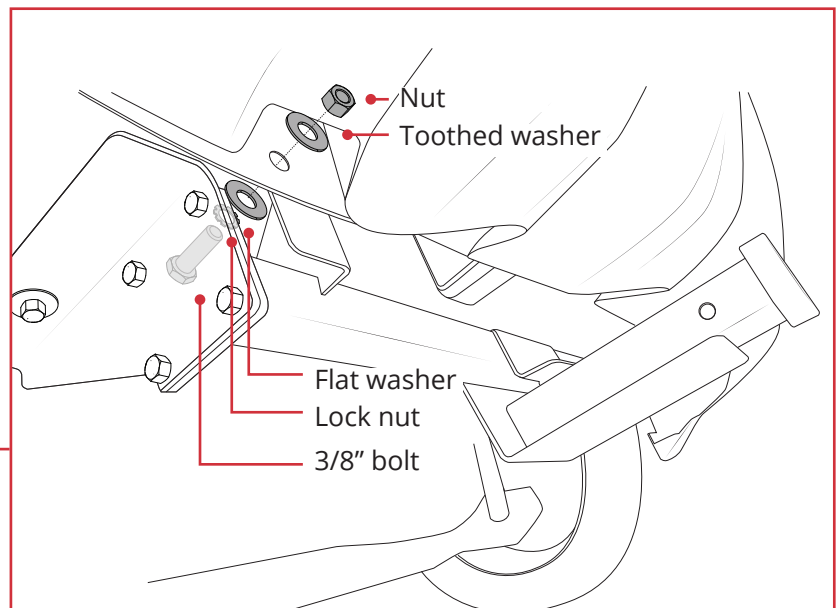

STEP 8

Use dimensions shown and follow the images below to mark the plastic panel.

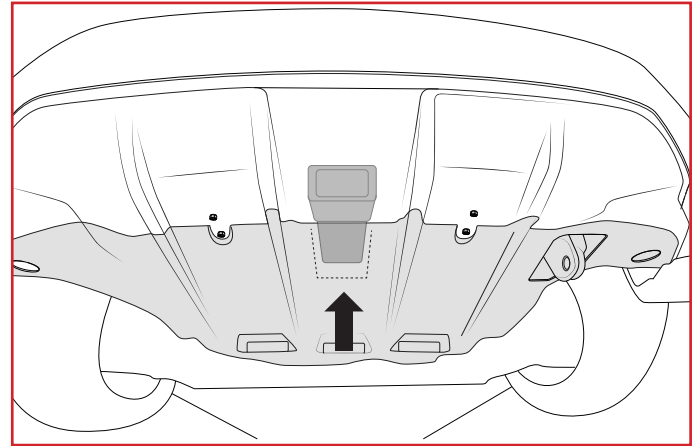
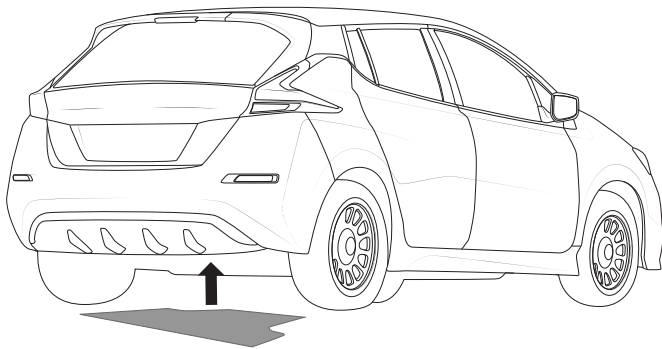

Mark across the moulding at the 200mm mark. Follow the contour down the right side as shown. The left is more angled.

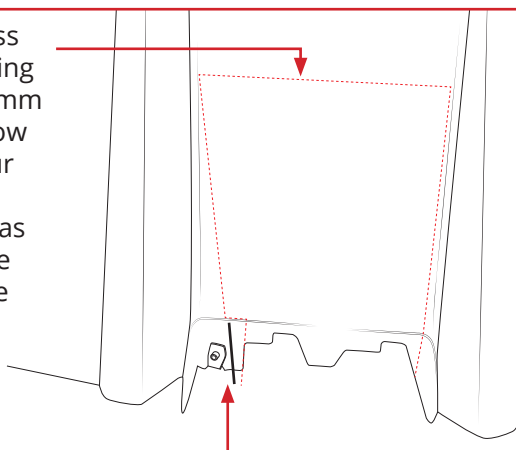

The left runs in line with the side of the metal thread at the bottom of the panel.

200mm

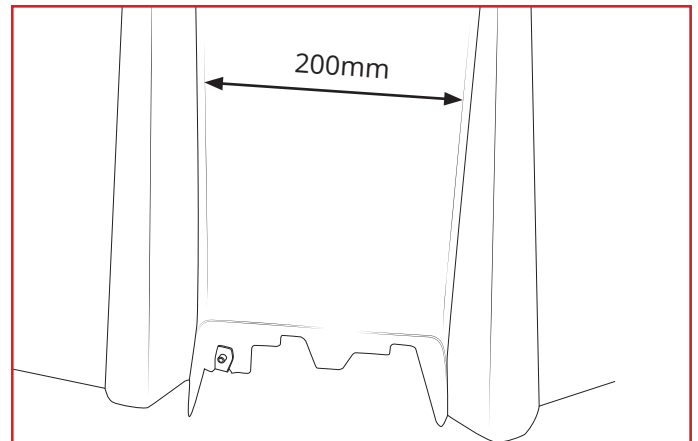

The general area to be worked in is where the moulding, at the centre of the plastic panel is 200mm wide.

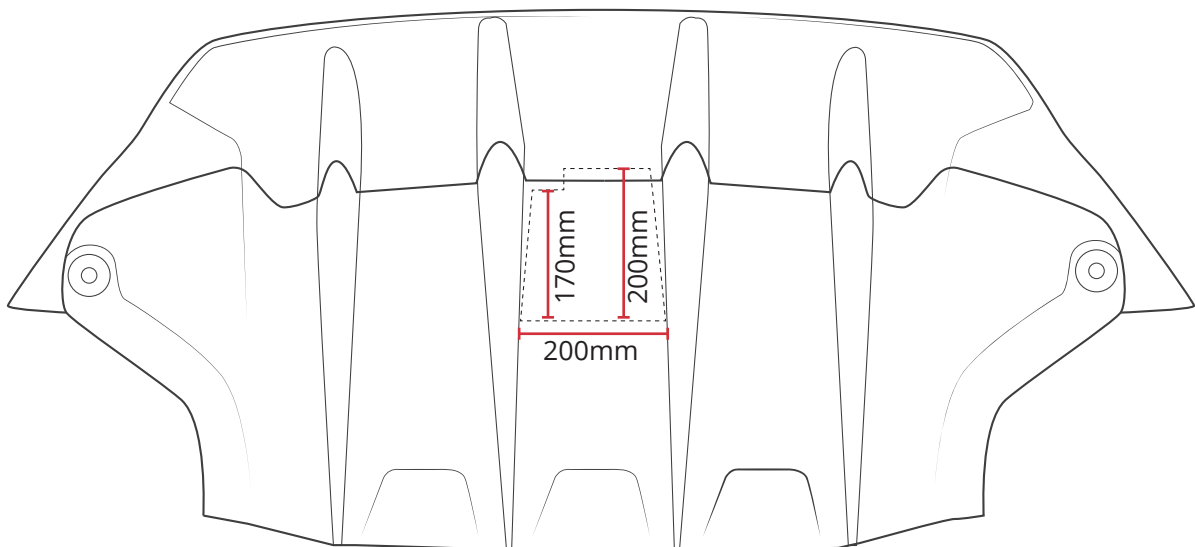

STEP 9

Carefully cut the plastic panel along the marks made previous.
Test fit and adjust as required.

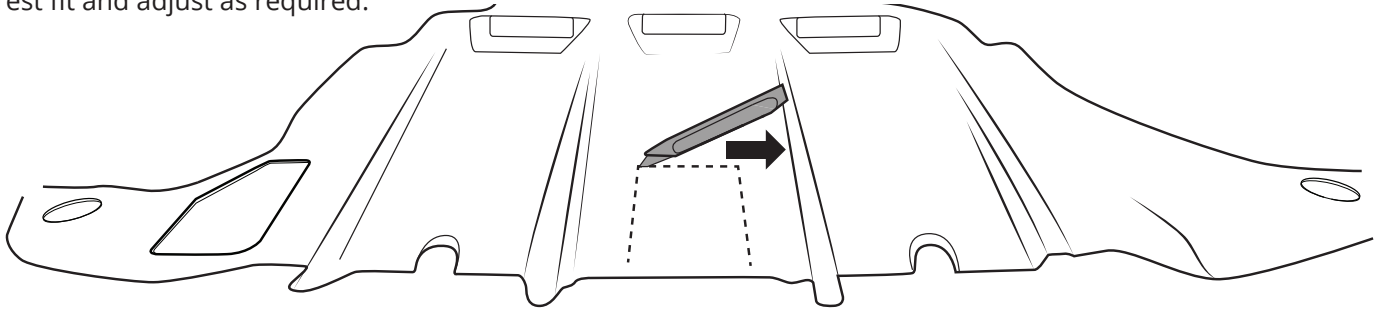

WIRING INFORMATION

STEP 1

Remove the right hand side tail light and attach the trailer plug wires as follows.

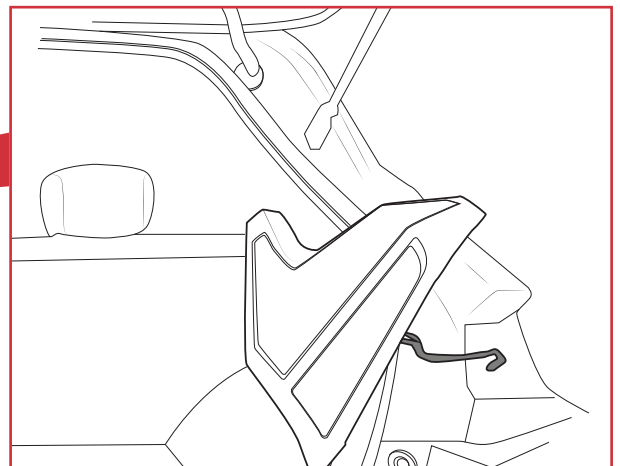
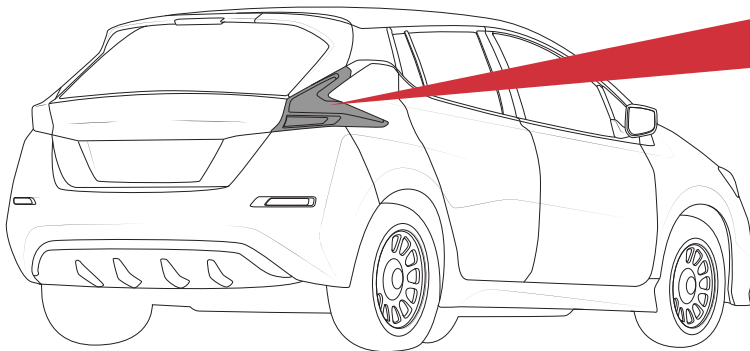

Splice the trailer plug wiring directly into the tail light wiring.
There is no need for an ECU.

Black - Earth

Green/white trace - Tail light

Green/yellow trace - Brake

Green wire (left side tail light) - Left side indicator

Green wire (right side tail light) - Right side indicator (run a wire to other light to connect)

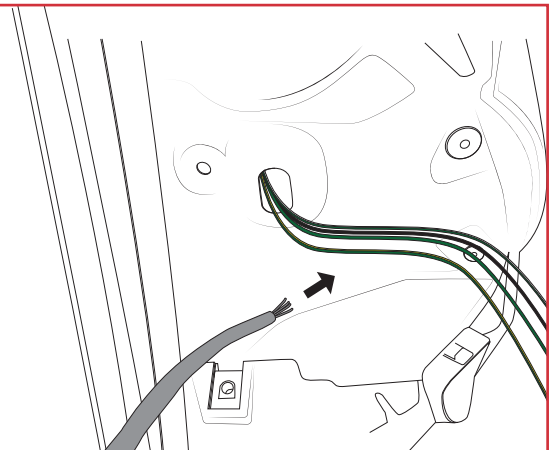

FINALISE FITMENT

Replace the rear tail light and plastic panel. Replace and re-tighten factory hardware.

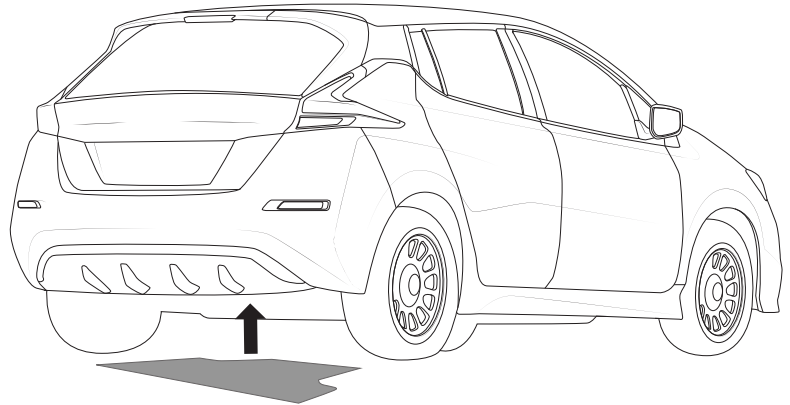

STEP 2

- A) Slide the towbar hitch into place.
- B) Use the pin to hold the hitch in place.
- C) Using an R clip, fix the pin in place.

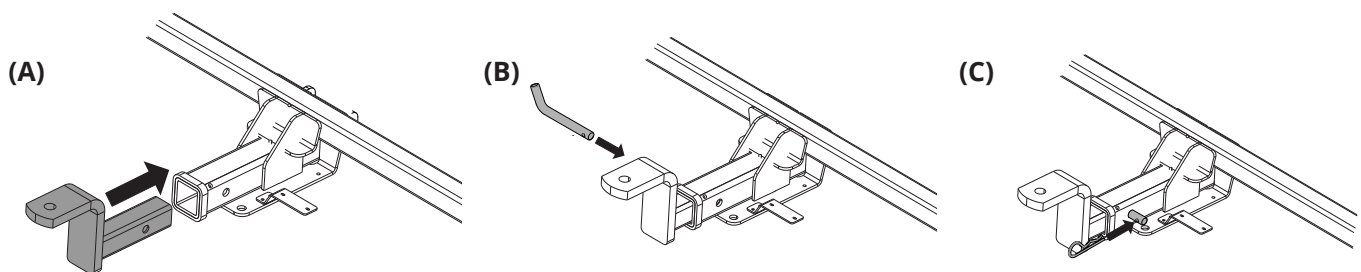

STEP 3

Install the load rating sticker provided, inside the drivers door.

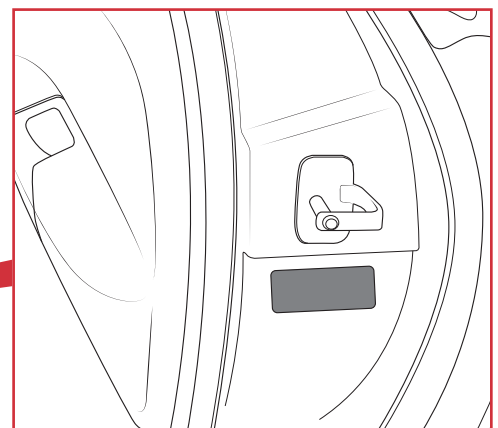
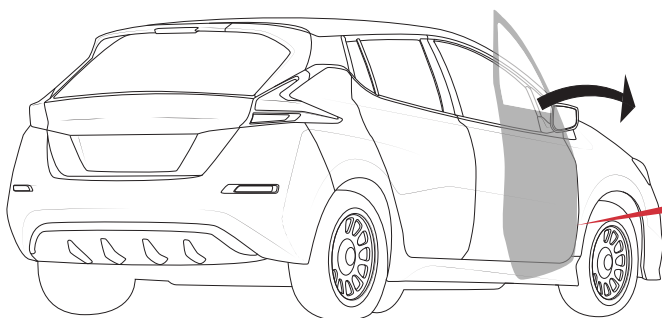

. EST 1956 .

CARASEL

TOWBARS

