



EST 1956  
**CARASEL**

**FITTING  
INSTRUCTIONS**

**KIA —  
EV9**

**P/N — K23G2**

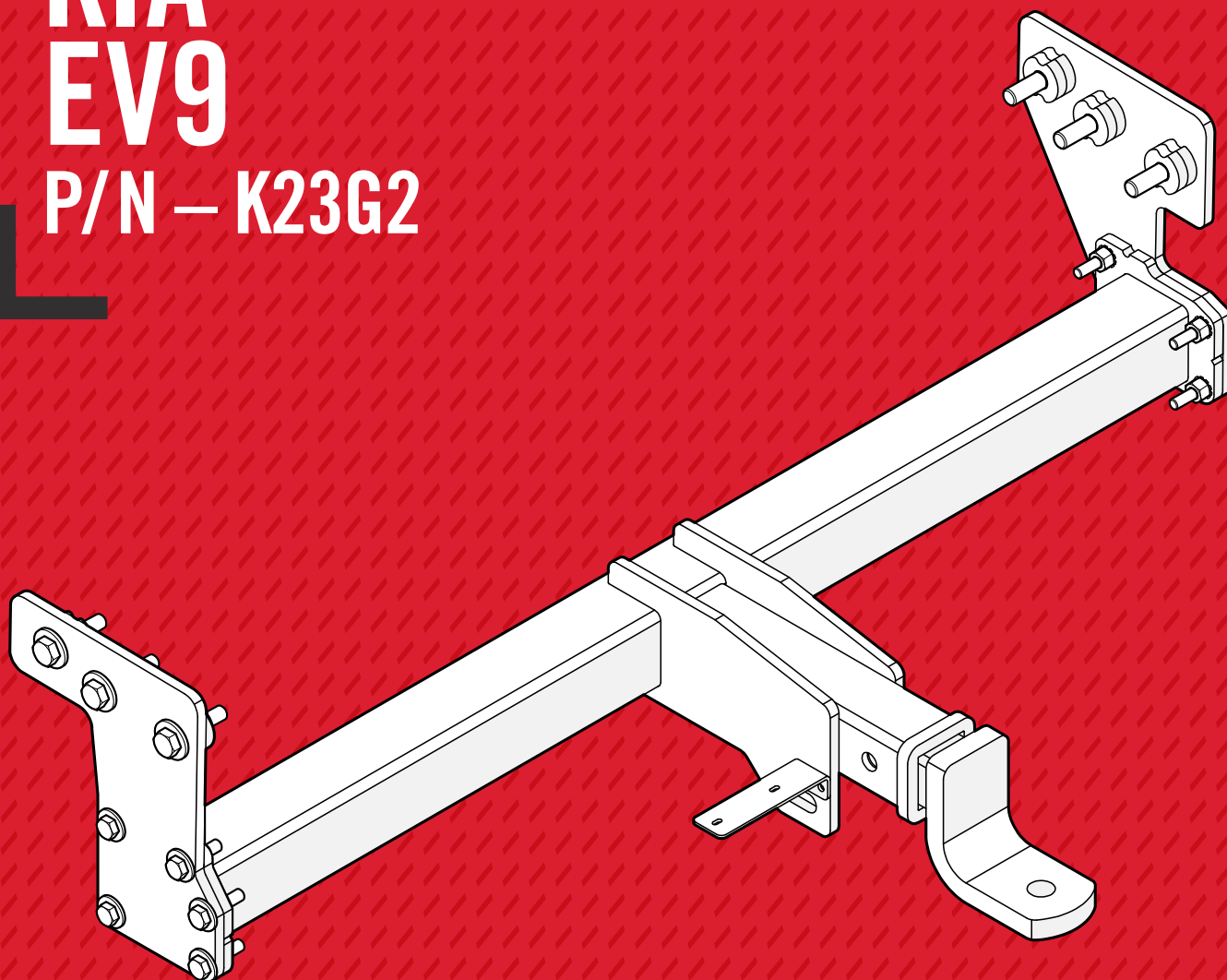

ISSUE #: 01  
ISSUE DATE: 18/04/24

**CONTROLLED**

# CONTENTS

<b>3</b>	<b>IMPORTANT INFORMATION</b>
<b>4</b>	<b>PARTS LIST</b>
<b>5</b>	<b>VEHICLE PREPARATION</b>
<b>7</b>	<b>TOWBAR INSTALLATION</b>
<b>10</b>	<b>WIRING STEPS</b>
<b>13</b>	<b>FINALISE FITMENT</b>
<b>17</b>	<b>TOWBALL USAGE</b>



# IMPORTANT INFORMATION

CHECK THE MAXIMUM TOWING CAPACITY OF YOUR VEHICLE AS STATED BY THE VEHICLE MANUFACTURER. DO NOT EXCEED THE MAXIMUM TOWING CAPACITY.

This product is for towing purposes only and must only be loaded as shown in your vehicle Owner's Manual.

- This towbar is NOT to be drilled, cut, welded, or modified in any way.
- Check behind chassis rail and body panels before drilling to ensure no hazards are present.
- All load ratings shown are under the assumption your trailer has a functional braking system installed.
- When installed in positions other than the one depicted in these instructions the Tow Ball Mount may interfere or obstruct certain features of your vehicle (tailgate opening, Chassis clearance, etc.)

## GENERAL:

- Before fitting this towbar read fitting instructions and check installation hardware is correct.
- Check that the towbar is suitable for the vehicle and be wary of any changes to the vehicle design that may conflict with the fitting of this towbar (Tray, Canopy, Suspension etc.)
- After drilling, blow any filings clear, remove any swarf and treat exposed metal with a rust inhibitor.

## TOWBAR MAINTENANCE AND CARE:

- It is recommended, when not in use, the Tow Ball Mount assembly and CLASS 4 Pin and Clip is stored inside the car away from moisture to prevent standing water from forming rust.
- Inspect to ensure, on regular basis, fasteners are torqued to the specifications below and in good condition.
- Ensure that the fitting instructions are read and understood prior to fitment.
- Place these instructions in the vehicle's glovebox after installation is completed.

# PARTS LIST

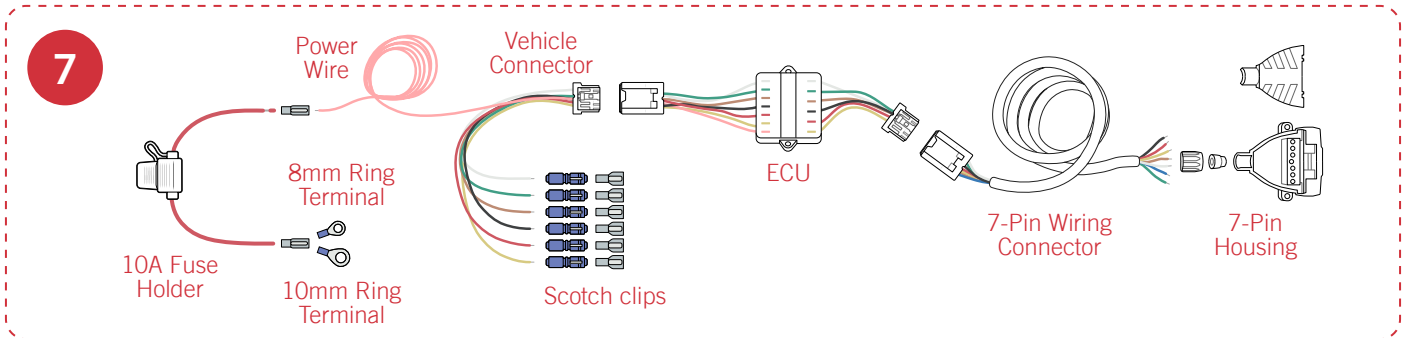
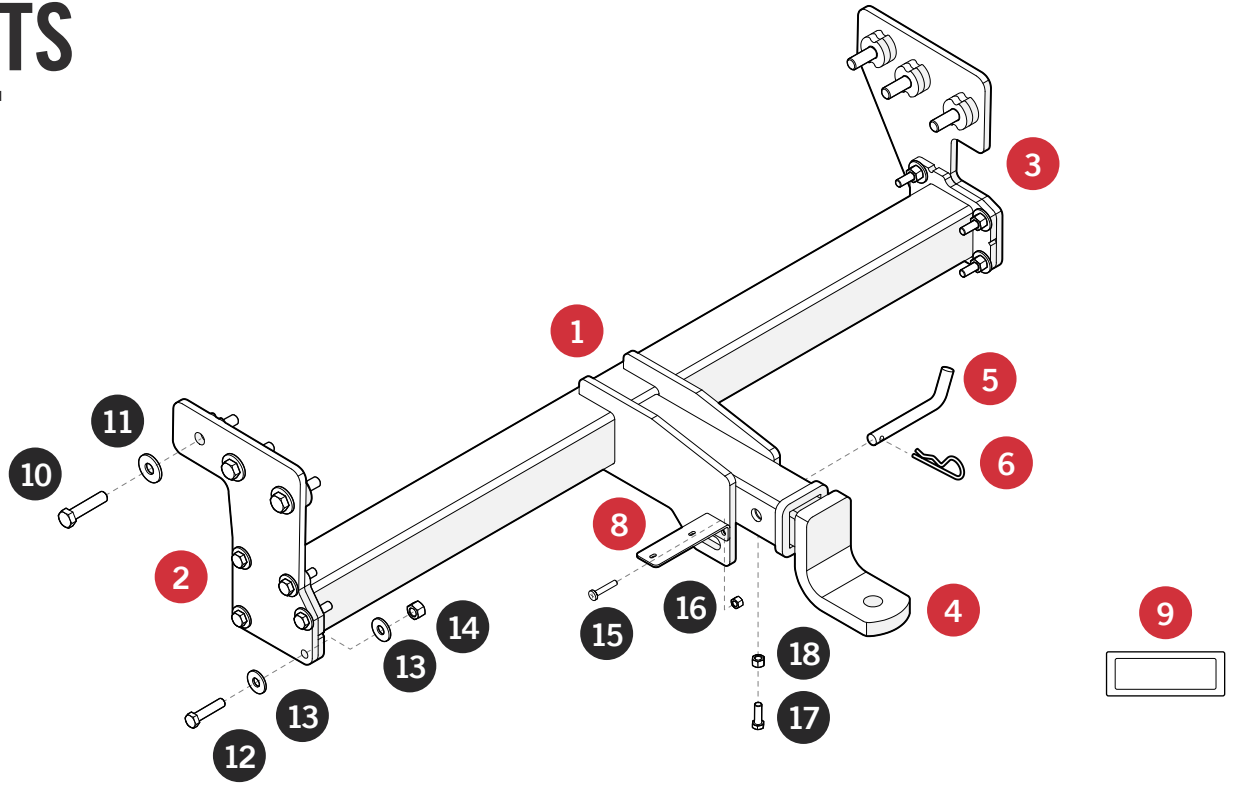

#	PART	QTY	#	HARDWARE	QTY
1	CROSS-BEAM	x1	10	M14 x 60mm x 1.5p BOLT	x6
2	LEFT CORNER BRACKET	x1	11	M14 FLAT WASHER	x6
3	RIGHT CORNER BRACKET	x1	12	M10 x 40mm x 1.25p BOLT	x9
4	TOWBAR HITCH	x1	13	M10 FLAT WASHER	x18
5	PIN	x1	14	M10 x 1.25p NUT	x9
6	R-CLIP	x1	15	M6 x 20mm PHILLIPS SCREW	x2
7	TOWBAR BYPASS KIT	x1	16	M6 NUT	x2
8	7-PIN BRACKET	x1	17	3/8" ANTI RATTLE BOLT	x1
9	LOAD RATING STICKER	x1	18	3/8" NUT	x1

<b>TOOLS REQUIRED</b> 	- 10mm Socket Wrench	- Trim Removal Tools	- Split Wire Loom 5m
	- 14mm Socket Wrench	- Jigsaw	
	- 17mm Socket Wrench	- Soldering Iron	
	- 1/2" Socket Wrench	- Zip ties x10	



# VEHICLE PREPARATION

STEP  
**01**

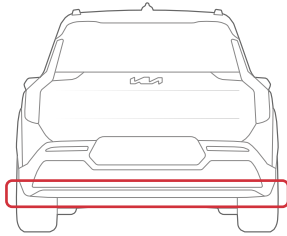

10mm Socket Wrench

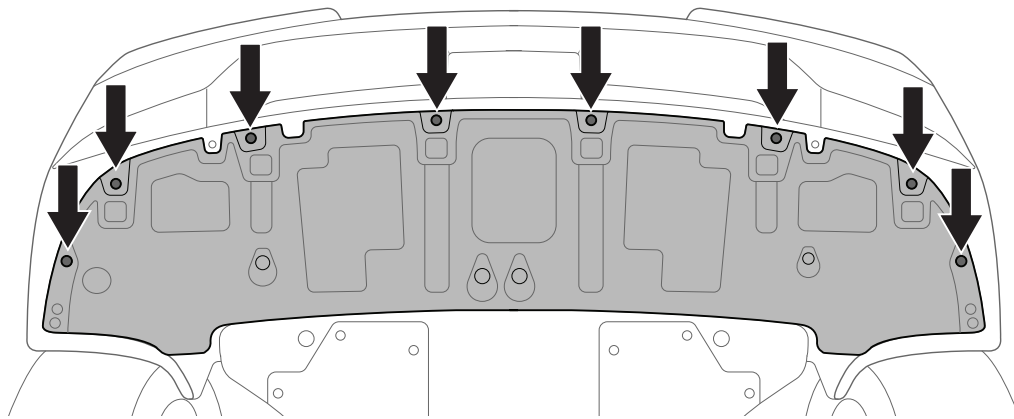
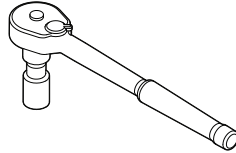

STEP  
**02**

Trim Removal Tool

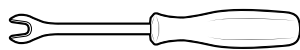

14mm Socket Wrench

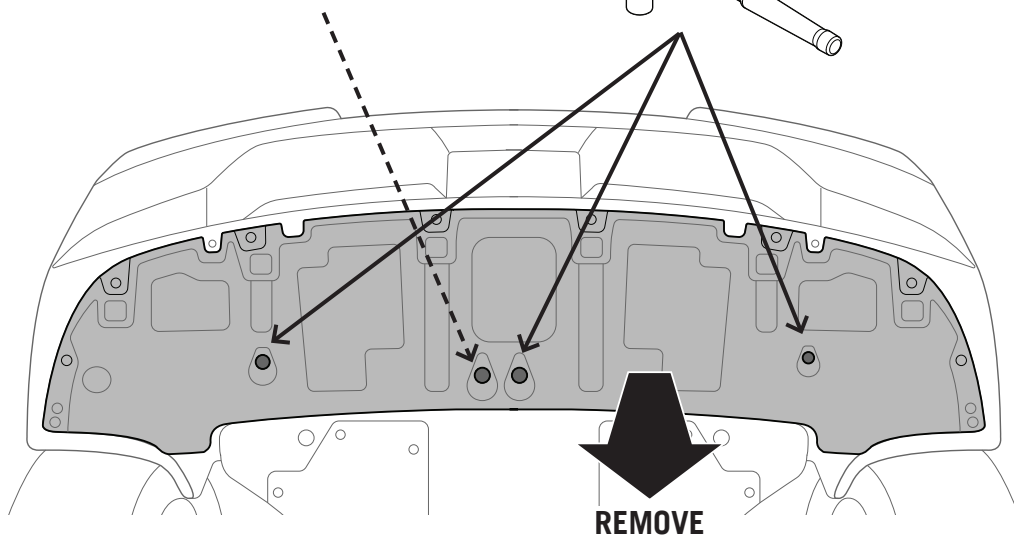
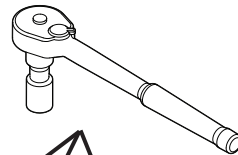

# STEP 03

Loosen all screws and bolts retaining the Tail Lights. Remove Tail lights by pulling outwards towards the rear of the vehicle.

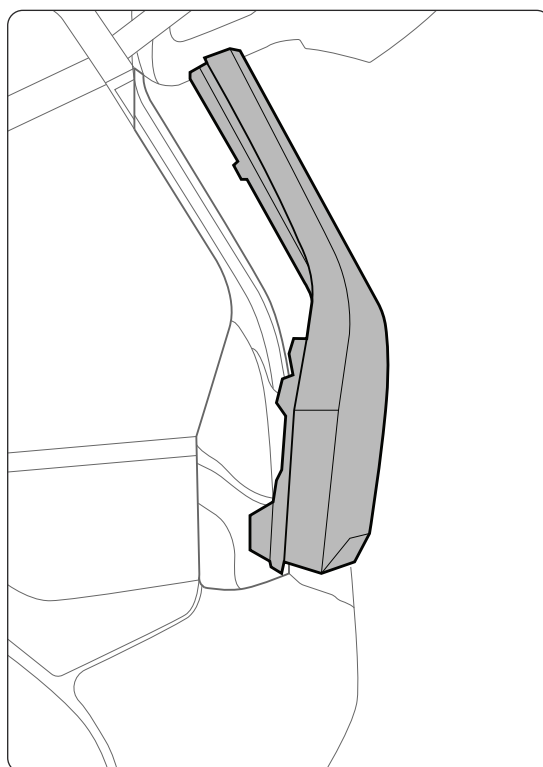
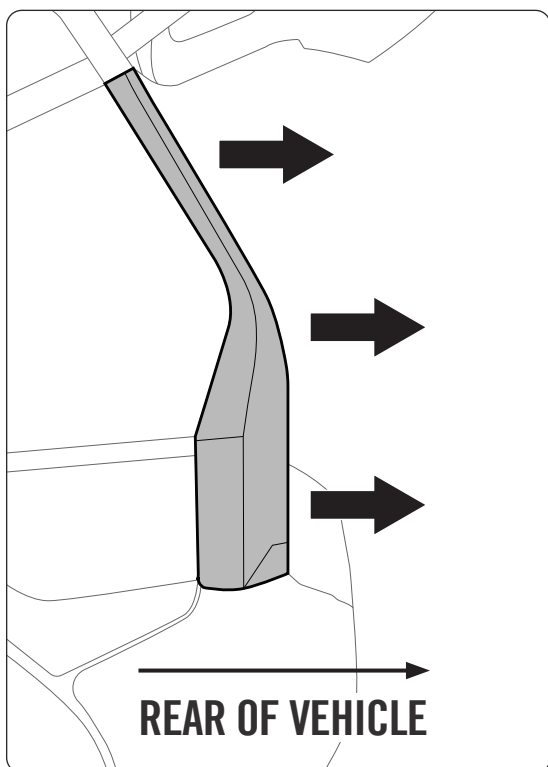
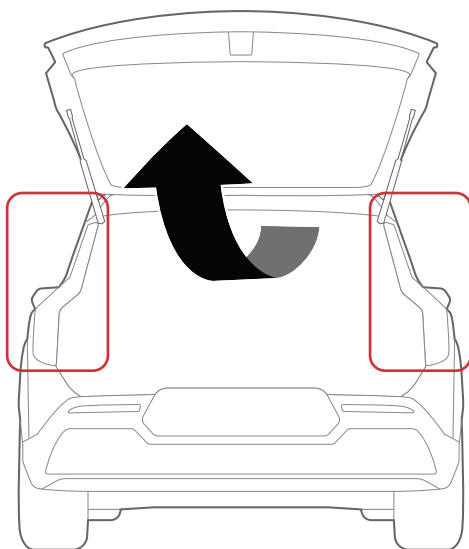



# TOWBAR INSTALLATION

**STEP 04** Install Side brackets **2** **3** into factory holes in chassis with hardware **10** **11**

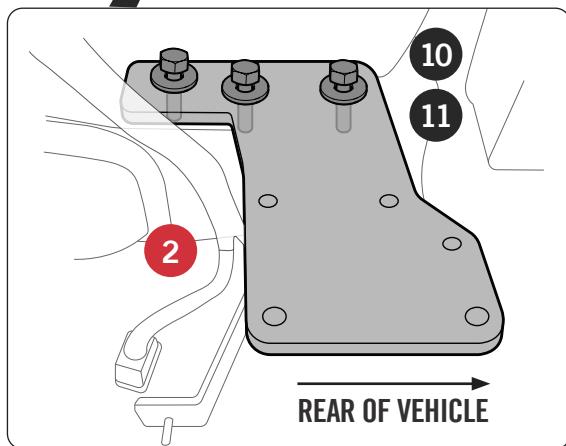
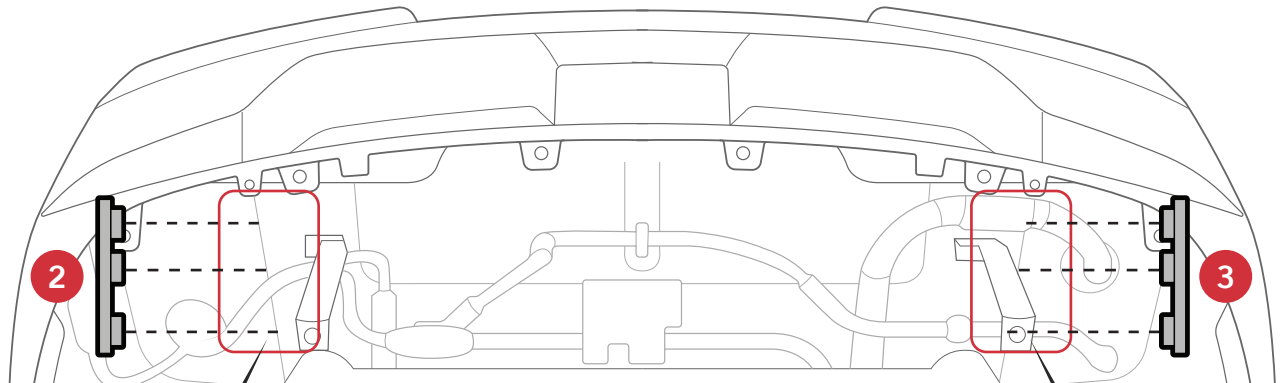

**LHS**

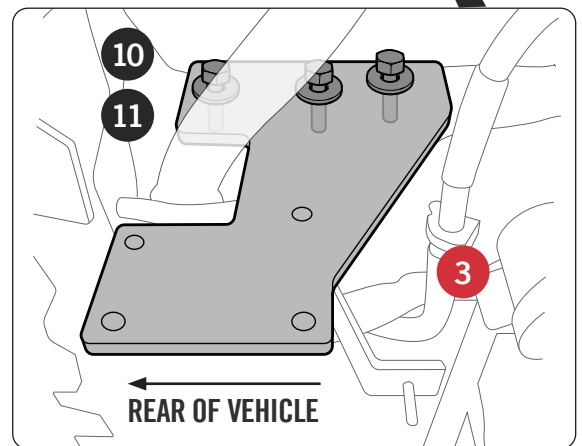

**RHS**

# STEP 05

NOTE: MINIMUM 2 PEOPLE REQUIRED:

Hold Cross bar **1** in place between Side brackets, and carefully cut Rear Vehicle Bumper to match towbar profile. Cut away enough material so that Cross bar holes line up with Side Bracket holes.

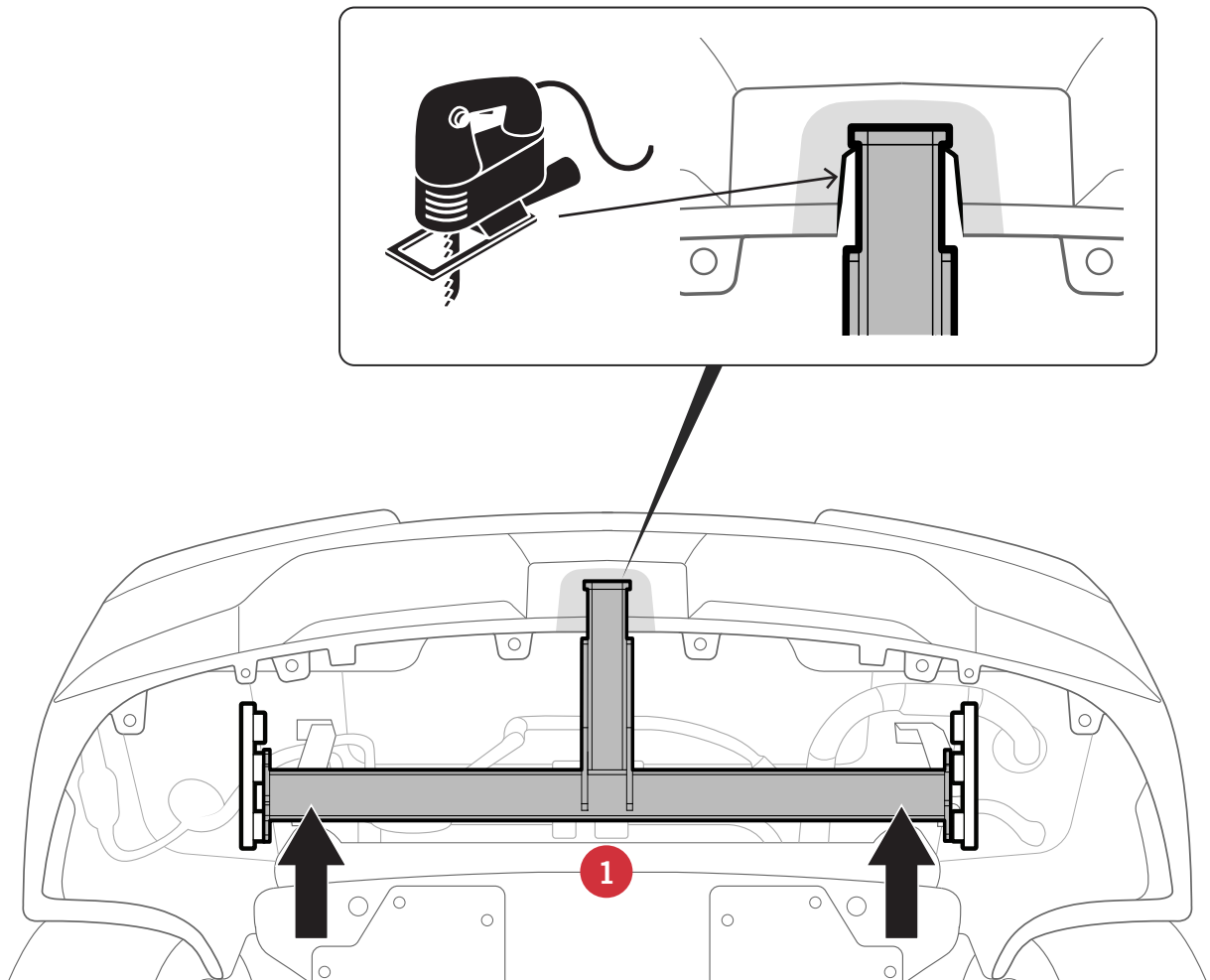

EXAMPLE:

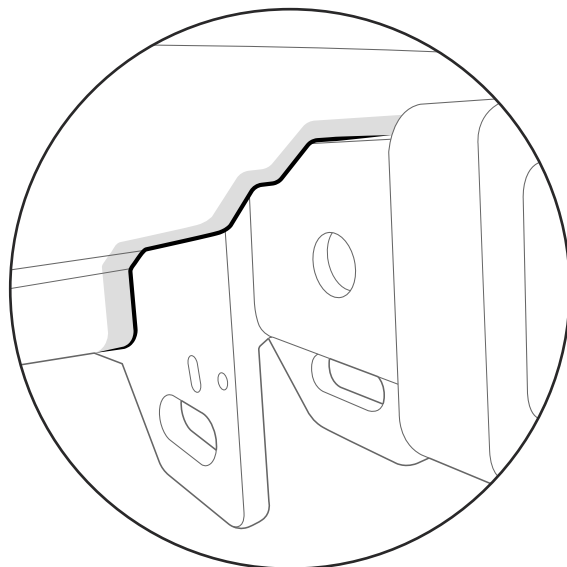





# STEP 06

Once Rear Vehicle Bumper has been cut to size, secure towbar to Side Brackets with hardware below.

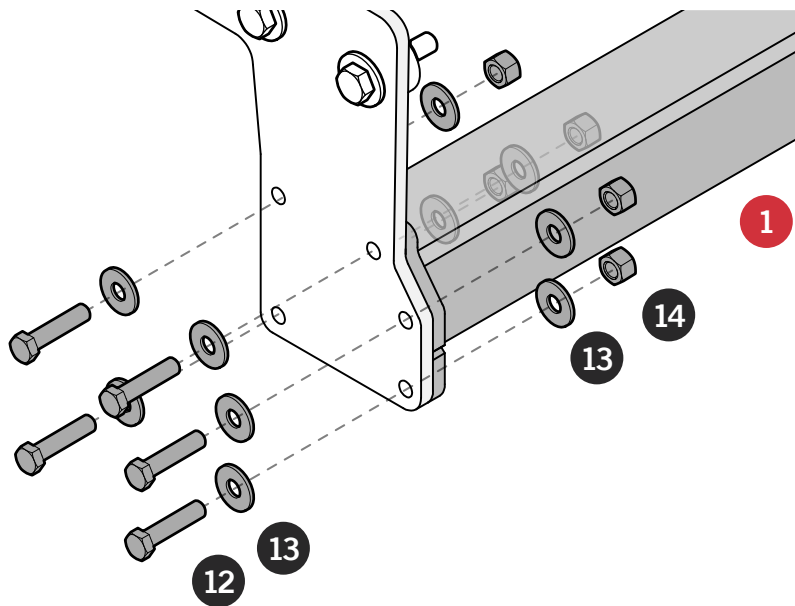
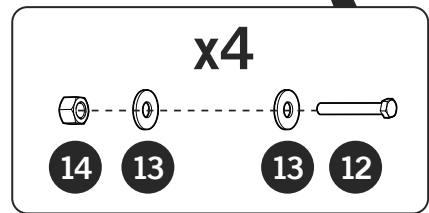
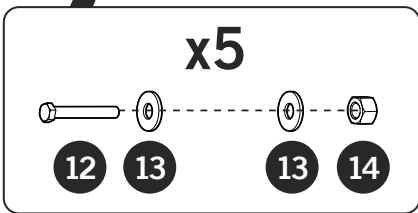
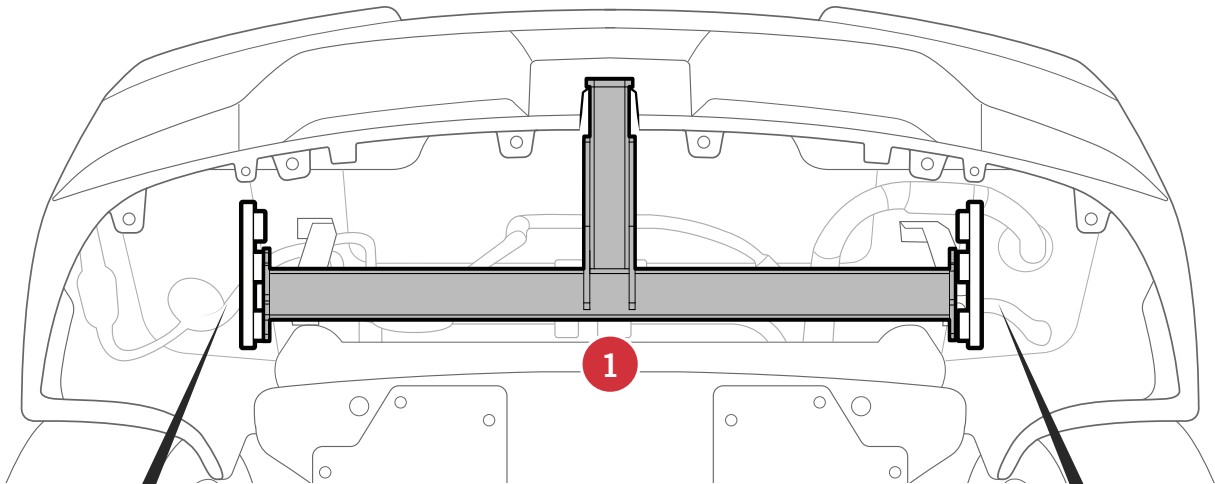

# WIRING STEPS

## STEP 07

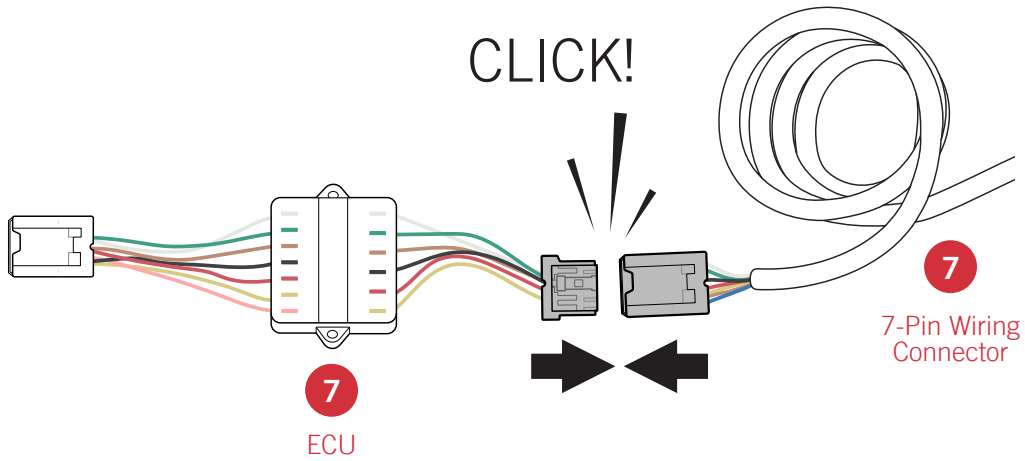

## STEP 08

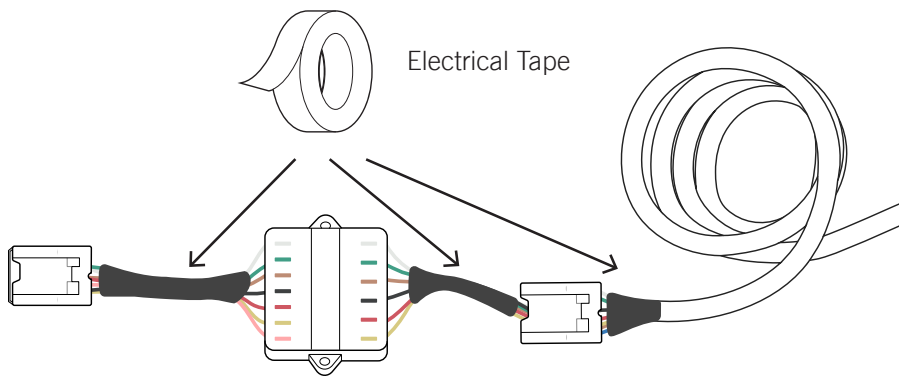

## STEP 09

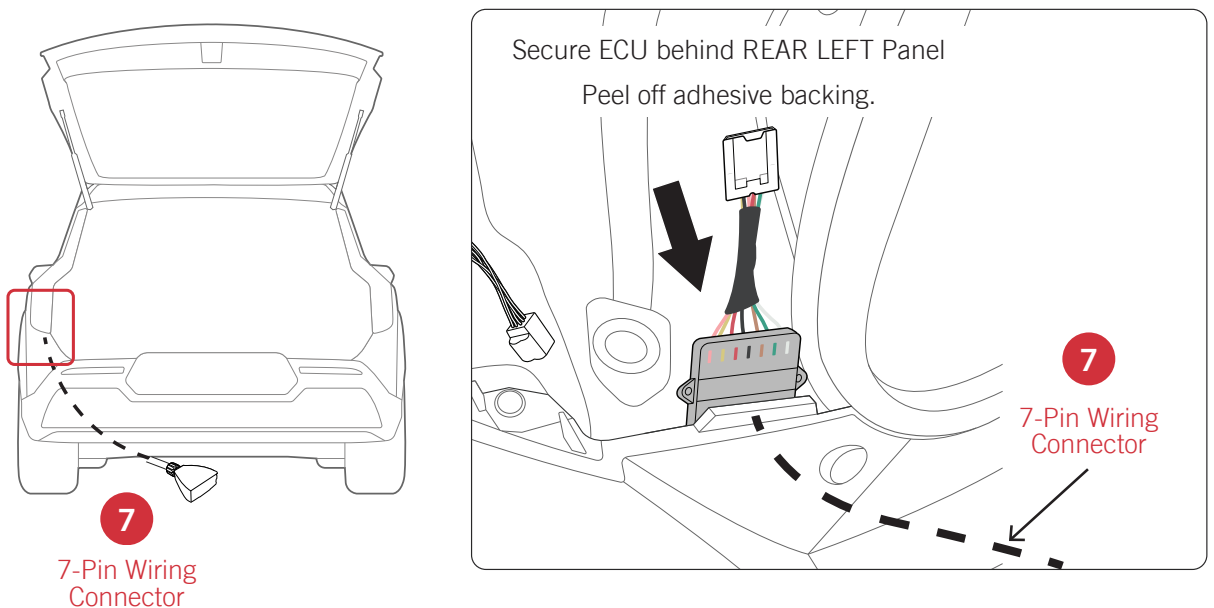

# STEP 10

## LHS LIGHT

Connect ECU wires to Vehicle wires as follows:

ECU	Vehicle
RED	> GREEN & ORANGE (Brake light)
YELLOW	> BLUE & ORANGE (Left Indicator)
BROWN	> GREEN & BLACK (Tail Light)
WHITE	> BLACK (Earth)

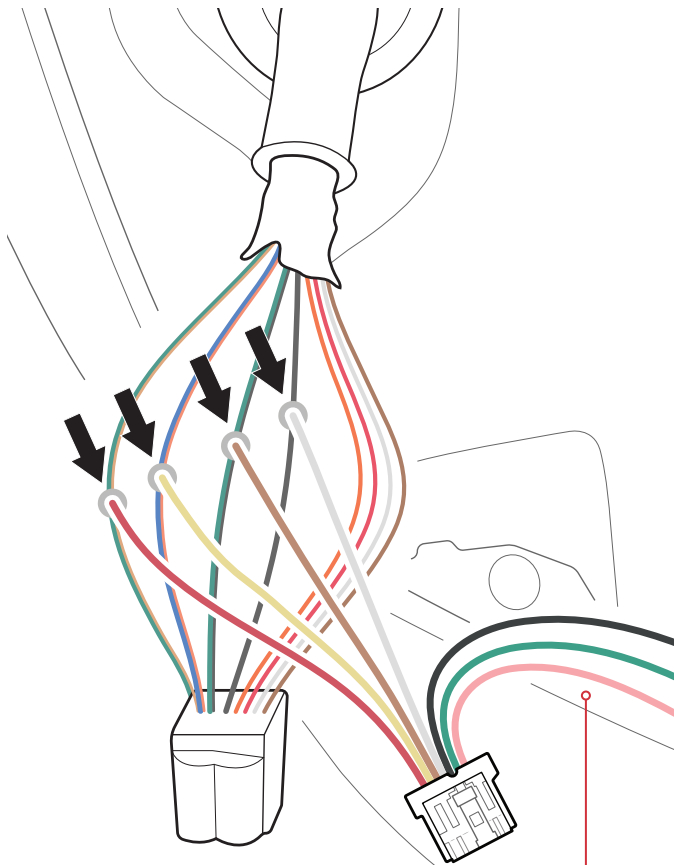

**7**  
Vehicle Connector

- Leave **Green** wire out for RHS Tail Light
- Leave **Pink** wire out for **STEP 11**
- **Black** wire not needed for this install.

## RHS LIGHT

**A.** Solder an Extension wire to **Green** ECU wire.

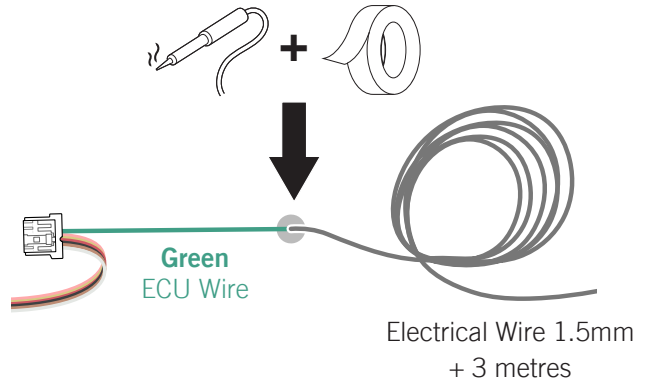

**B.** Feed wire down LHS Tail Light cavity, across the vehicle rear, and back up through the RHS Tail Light cavity. Secure wire route with zip-ties.

**IMPORTANT:** Avoid sharp edges and areas with heat.

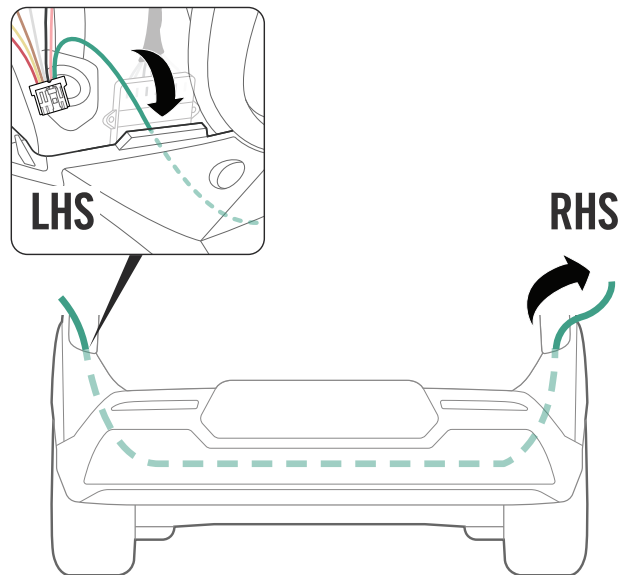

**C.** Connect **Green** wire to **RED & ORANGE** wire on RHS Tail-light harness.



# STEP 11

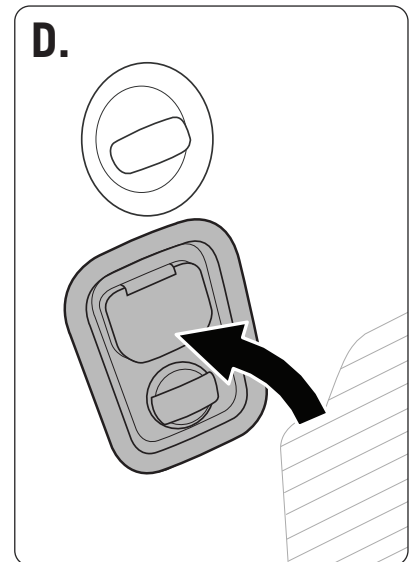
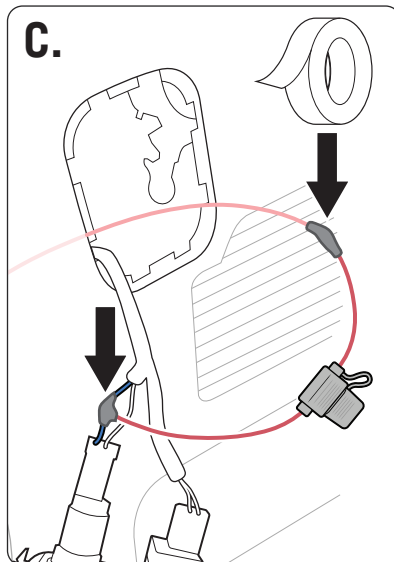
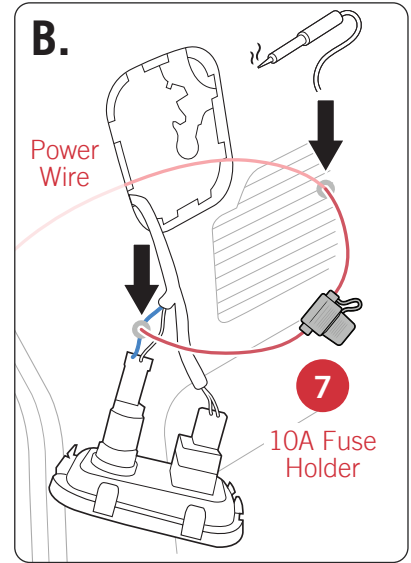
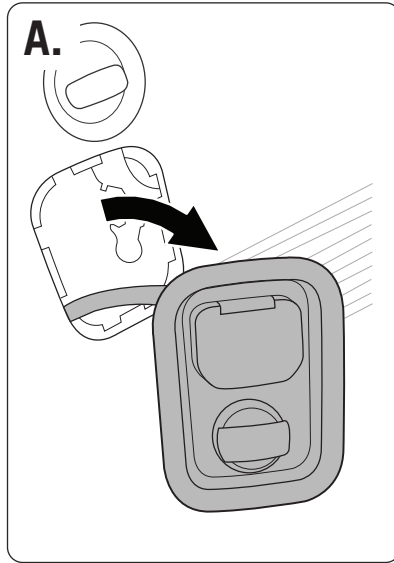
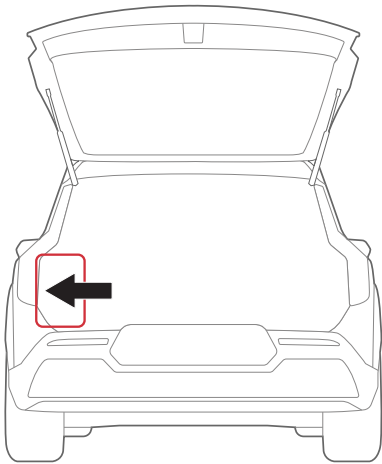

# STEP 12

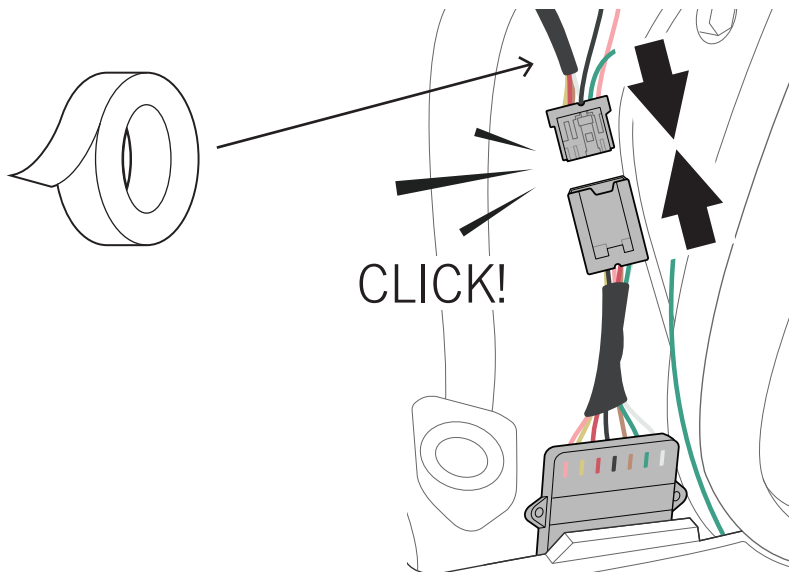



# FINALISE FITMENT

## STEP 13

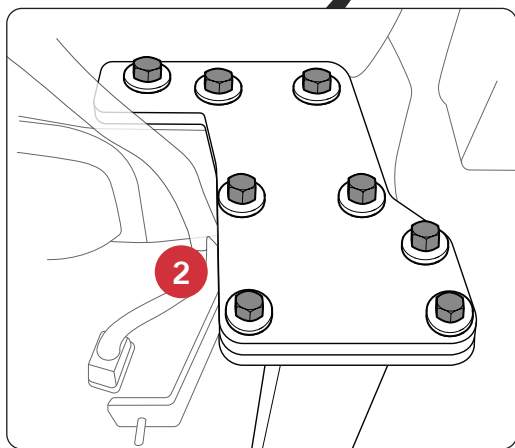
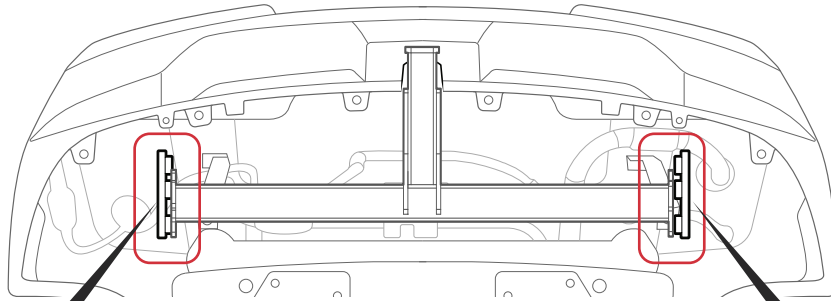

**M14: 150NM**

22mm Socket Wrench  
+ Torque Wrench

**M10: 70-90NM**

17mm Socket Wrench  
+ Torque Wrench

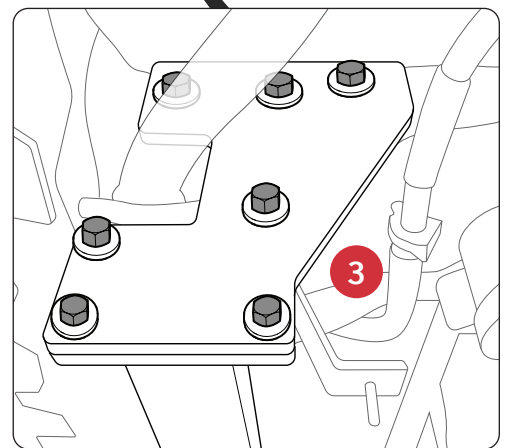

## STEP 14

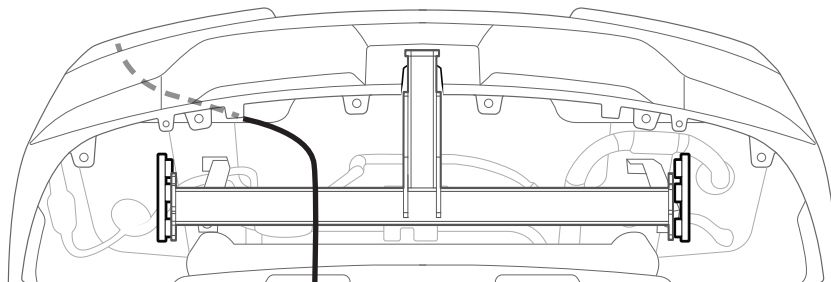

**7**

7-Pin Wiring  
Connector

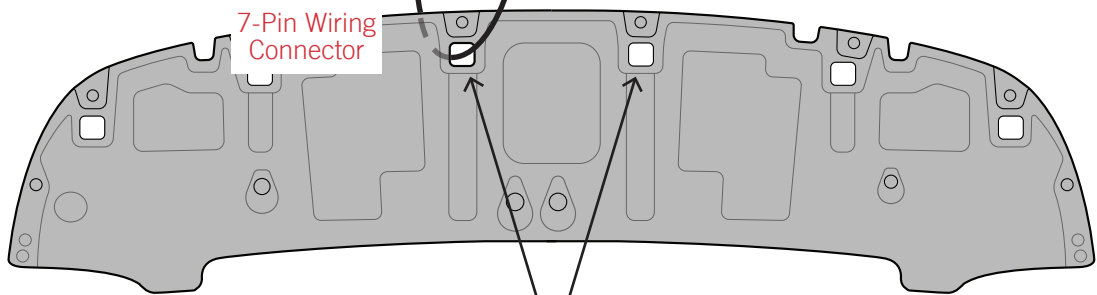

Feed Wire through Left or Right square hole.

Left shown as example.

# STEP 15

Assemble 7-Pin Housing onto wire.

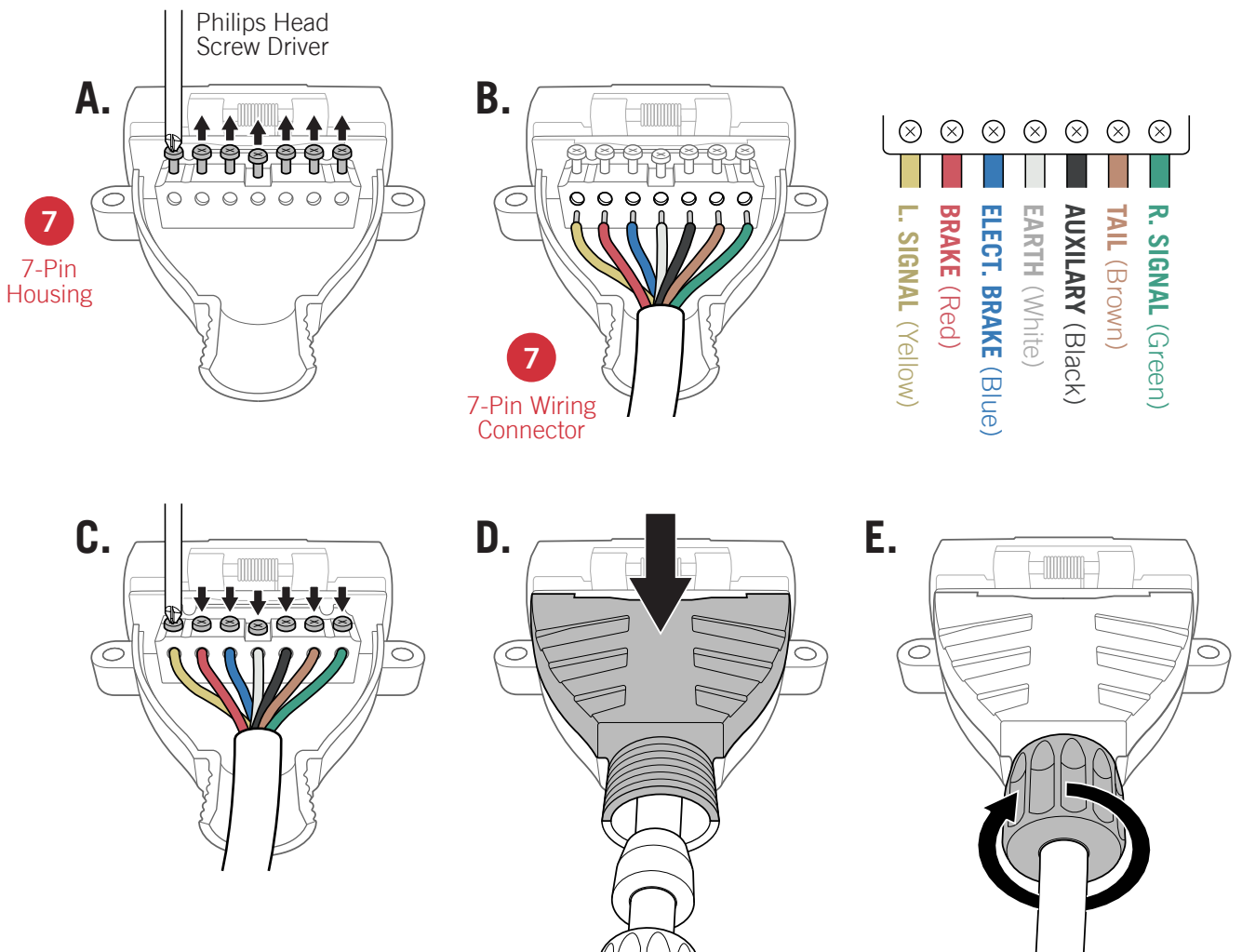
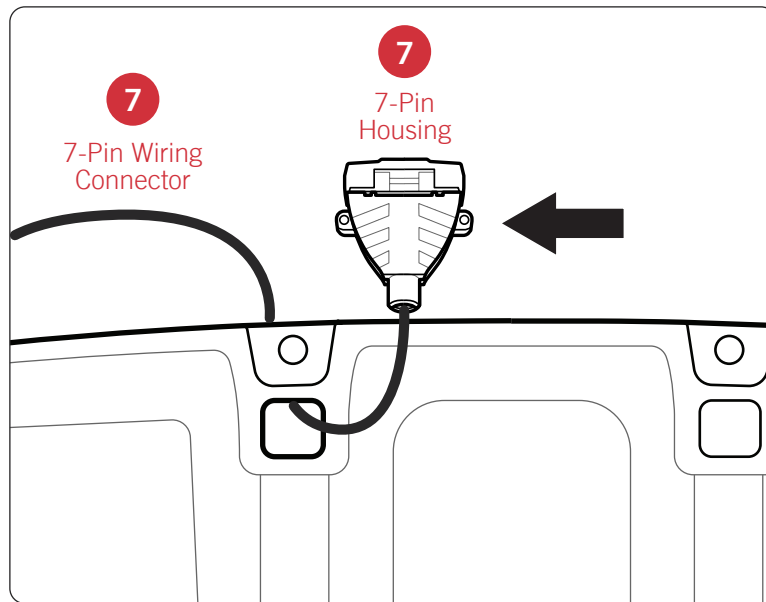



# STEP 16

Assemble Bracket on same side as 7-Pin Wire.  
Left shown as example.

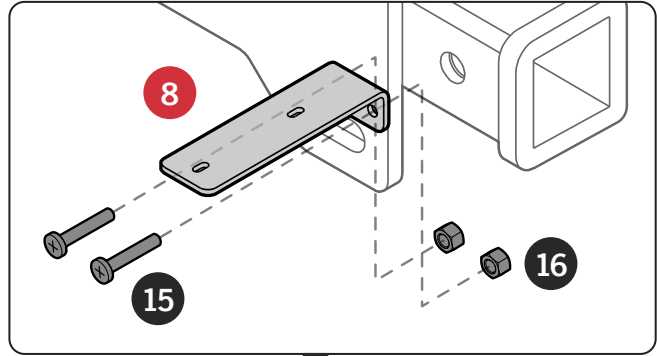

**IMPORTANT:** Zip-tie excess wire to the towbar / vehicle body. Avoid sharp edges and areas with heat.

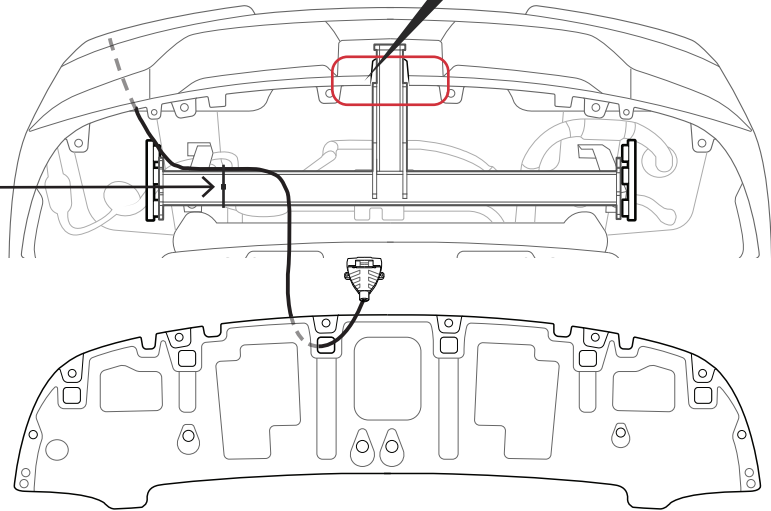

# STEP 17

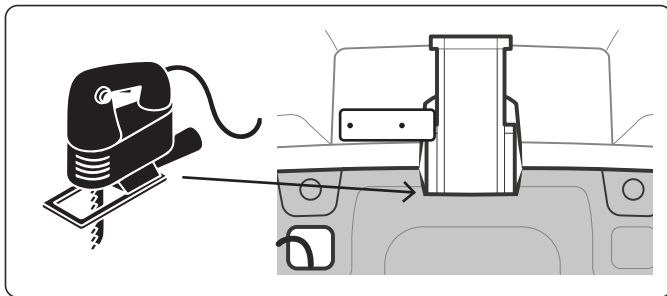

EXAMPLE:

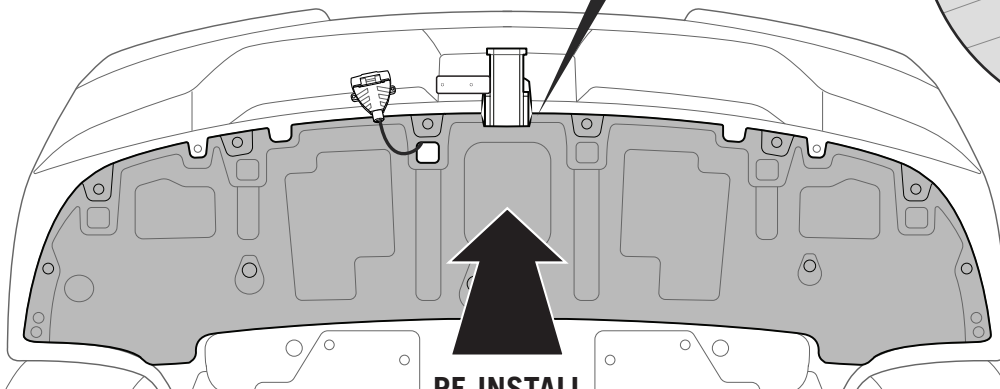
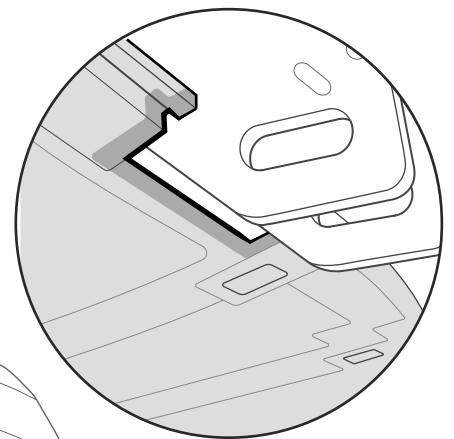

# STEP 18

Attach 7-Pin Plug with M6 Hardware.

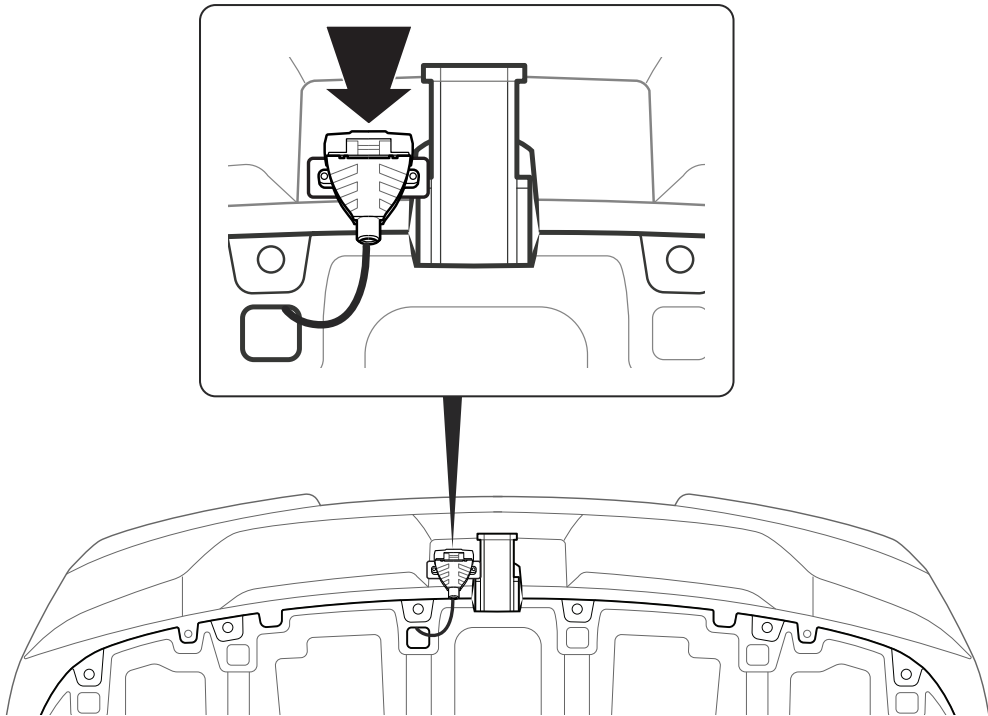

# STEP 19

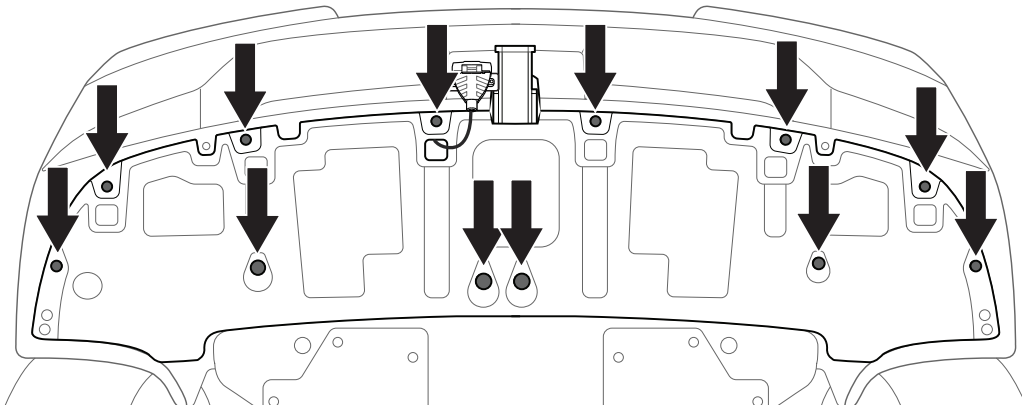

10mm Socket Wrench

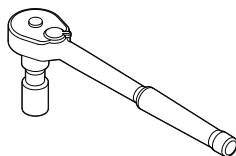

14mm Socket Wrench

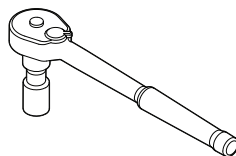

Trim Removal Tool

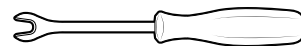

**COMPLETE STEPS 01 TO 03 IN REVERSE ORDER.**





# TOWBALL USAGE

## STEP 20

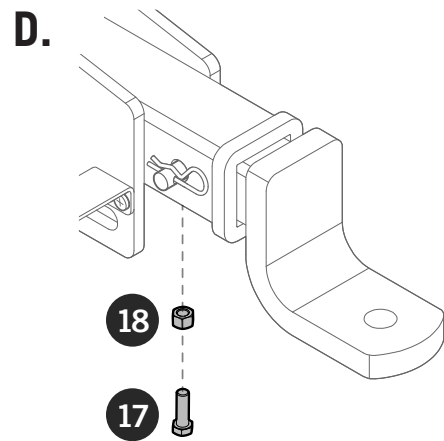
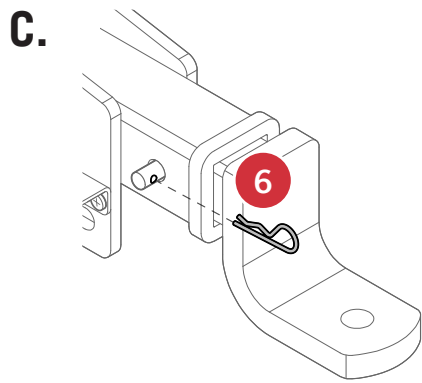
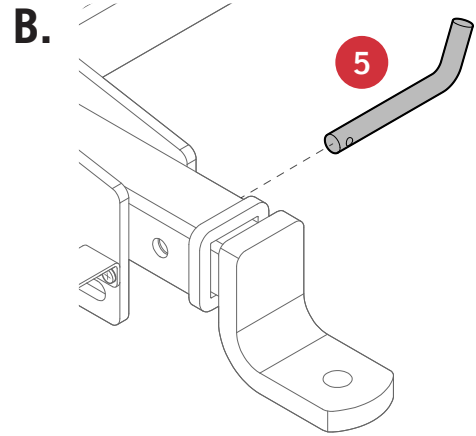
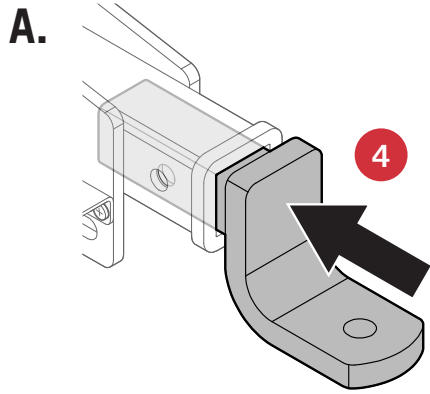

## STEP 21

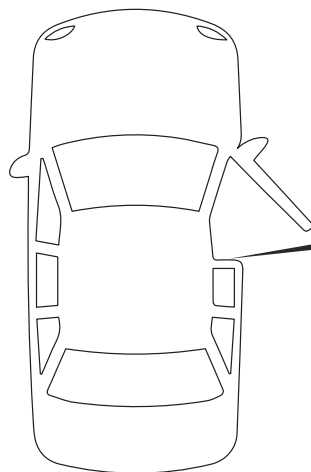

Place load rating sticker inside the driver's door.

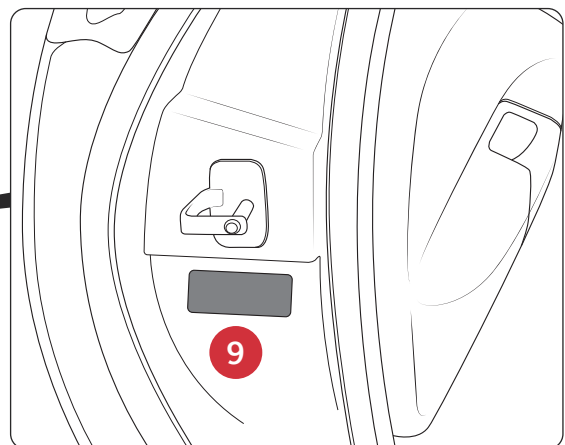



## We're here to help

Want to chat? Call **1800 869 227**  
or email [hello@carasel.com.au](mailto:hello@carasel.com.au)

Learn more about us at  
[carasel.com.au](http://carasel.com.au)



**100% AUSTRALIAN  
MADE AND OWNED**



**DRIVE AWAY  
LIFETIME WARRANTY**



**MANUFACTURED TO  
AUSTRALIAN STANDARD**