

. EST 1956 .

CARASEL

TOWBARS

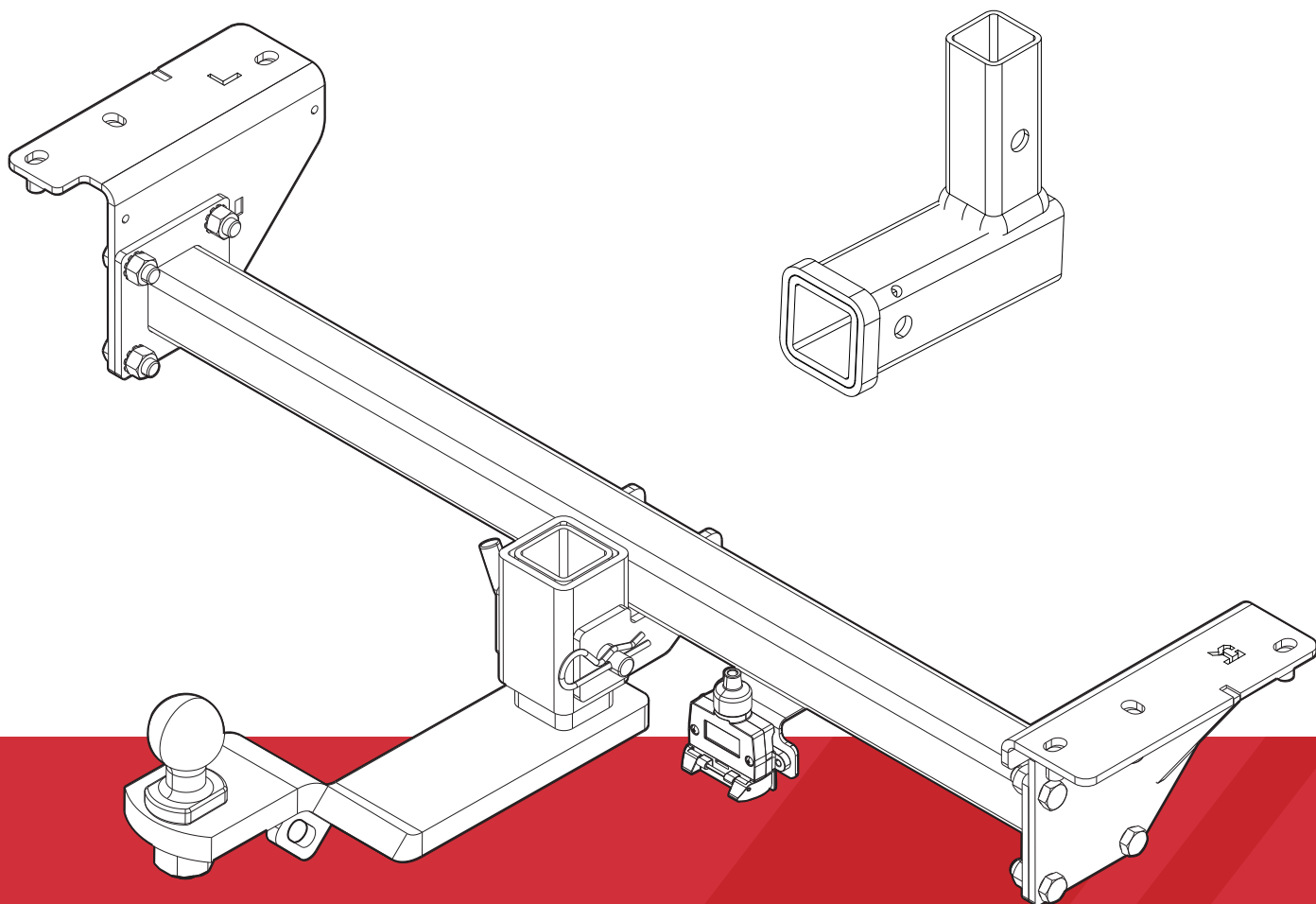

BYD – ATTO 3
P/N – BYD2



LIFETIME
WARRANTY

Issue03

PARTS LIST

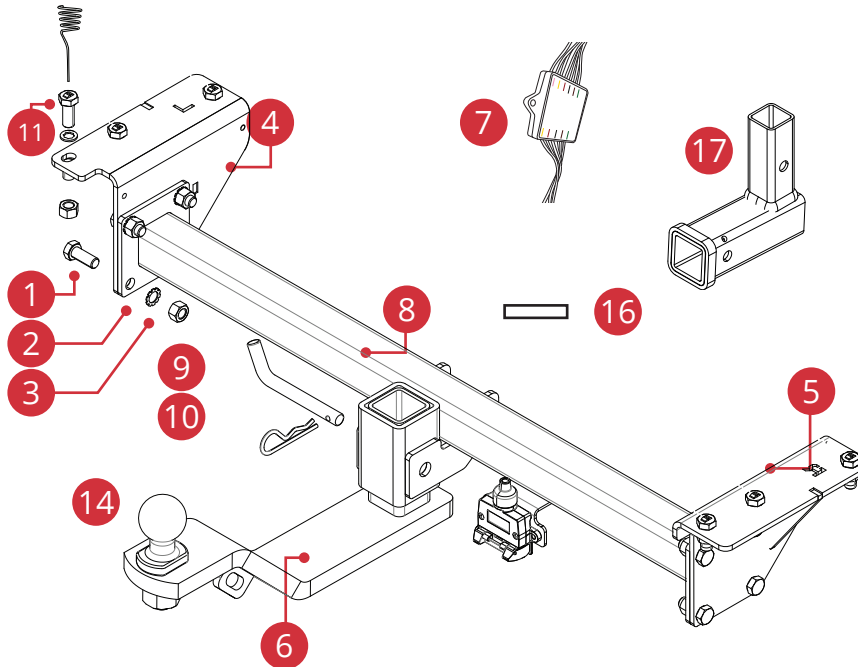

Tools required
 Cold galvanising paint.
 Power drill.
 Trim removal tool.
 10.5mm drill bit.
 18mm socket wrench.

PN	DESCRIPTION
1	M12X35mm HEX SCREW
2	M12 TOOTHED WASHER
3	M12 HEX NUT
4	VERTICAL BRACKET LEFT
5	VERTICAL BRACKET RIGHT
6	TOWBAR HITCH
7	TOWBAR BYPASS KIT
8	CENTRE FRAMEWORK
9	PIN
10	R-CLIP
11a	SPRING FISHING WIRE
11b	3/8" BOLT
11c	LOCK WASHER
11d	FLAT WASHER
12	SHIN PROTECTOR
13	HITCH COVER
14	TOWBALL 50MM CHROME
15	PLASTIC CHROME TOWBALL COVER
16	LOAD RATING LABEL
17	BIKE ADAPTOR

IMPORTANT INFORMATION

This product is for towing purposes only and must only be loaded as shown in your vehicle Owner's Manual.

- This towbar is NOT to be drilled, cut, welded, or modified in any way.
- Check behind chassis rail and body panels before drilling to ensure no hazards are present.
- All load ratings shown are under the assumption your trailer has a functional braking system installed.
- When installed in positions other than the one depicted in these instructions the Tow Ball Mount may interfere or obstruct certain features of your vehicle (tailgate opening, Chassis clearance, etc.)

General:

- Before fitting this towbar read fitting instructions and check installation hardware is correct.
- Check that the towbar is suitable for the vehicle and be wary of any changes to the vehicle design that may conflict with the fitting of this towbar. (Tray, Canopy, Suspension etc.)
- After drilling, blow any filings clear, remove any swarf and treat exposed metal with a rust inhibitor.

Towbar Maintenance and Care:

- It is recommended, when not in use, the Tow Ball Mount assembly and CLASS 4 Pin and Clip is stored inside the car away from moisture to prevent standing water from forming rust.
- Inspect to ensure, on regular basis, fasteners are torqued to the specifications below and in good condition.
- Ensure that the fitting instructions are read and understood prior to fitment.
- Place these instructions in the vehicle's glovebox after installation is completed.

STEP 1

Locate the three holes on the vehicle chassis member, in the area shown.

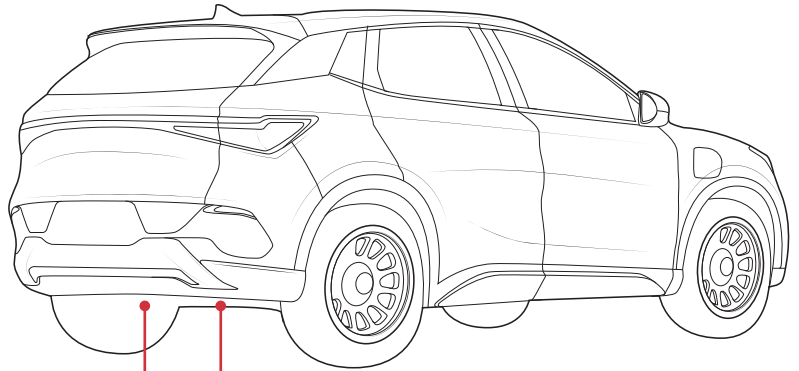
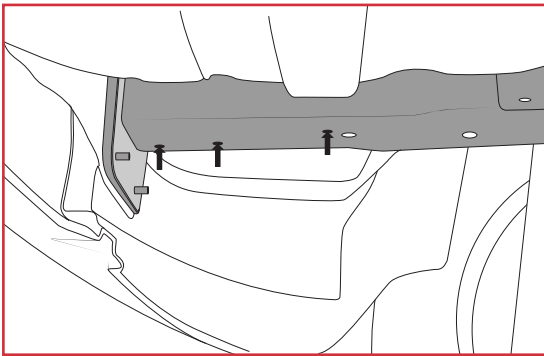

STEP 2

Drill out the 3 holes shown using a 10.5 drill bit (each side of the vehicle). It should just remove the body sound deadener.

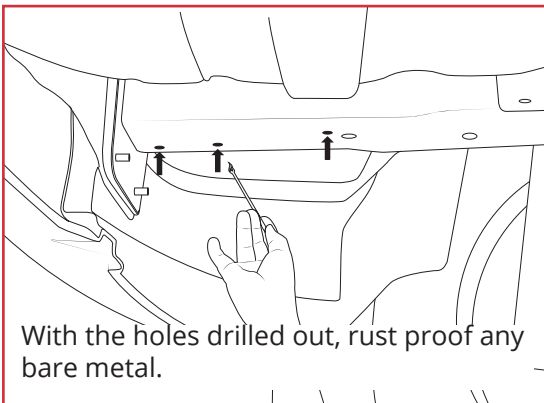

With the holes drilled out, rust proof any bare metal.

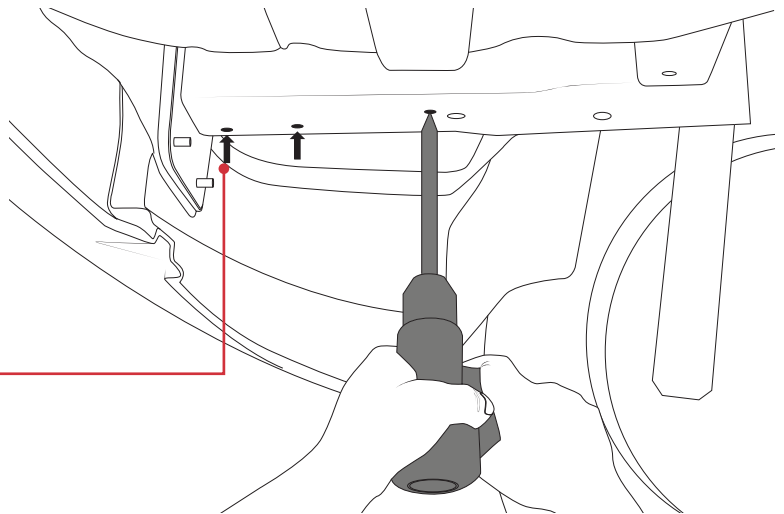

STEP 3

Remove foam tape covering side access holes on the chassis.

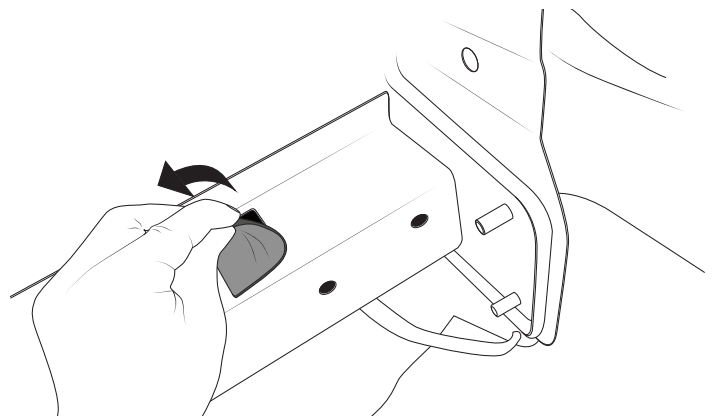

STEP 4

Slide a large flat washer, lock washer and then wind on 3/8" bolt at least 4-5 full revolutions, onto the spring fishing wire tools.

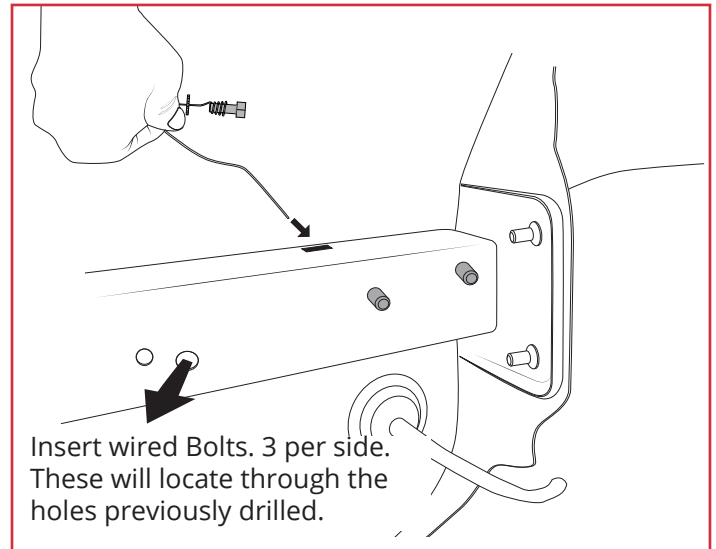
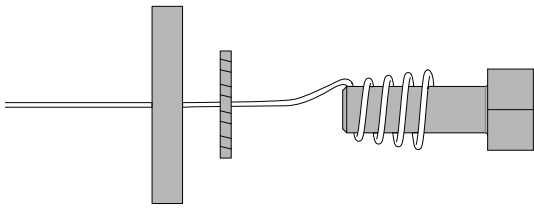

STEP 5

Position Left or Right side vertical brackets over the bolts and finger tighten with 3/8" nuts and lock washers.

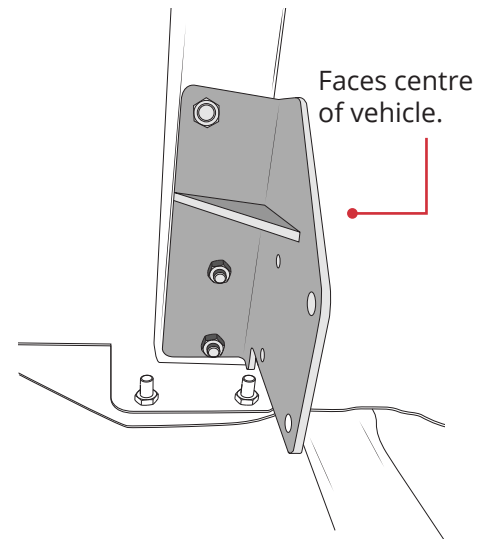
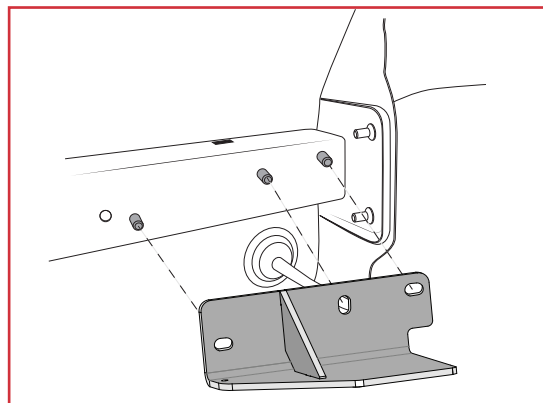

STEP 6

Position horizontal cross beam. Assemble with M12x35 bolts, lock washers and nuts. Tighten completely to 70Nm.

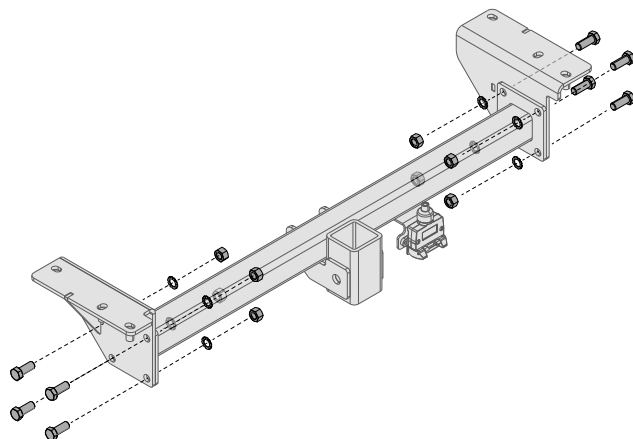

STEP 7

Tighten the hardware from step 5 to Chassis 70Nm.

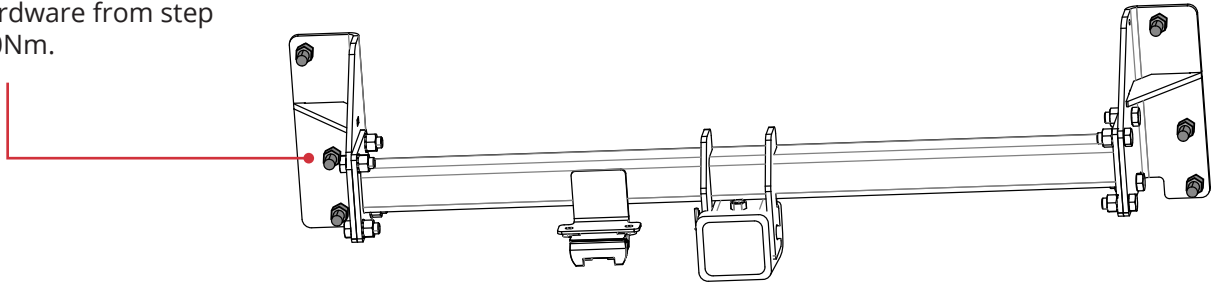

WIRING INFORMATION

STEP 1

Open the boot of the vehicle.
Remove both bolts either side in the plastic panel.

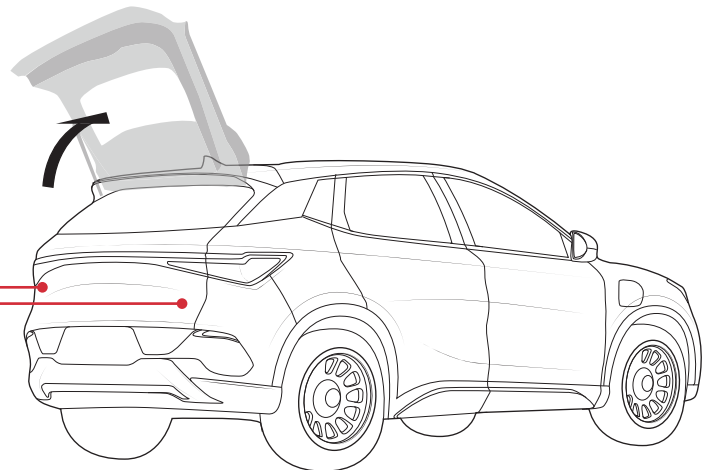
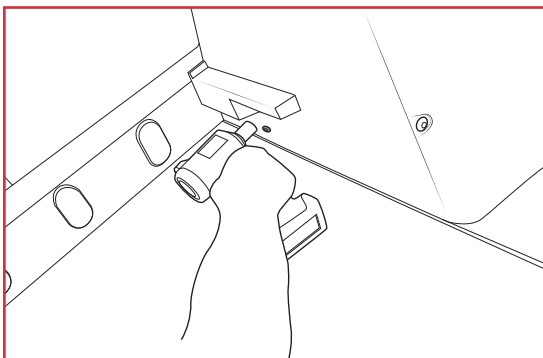

STEP 2

Carefully lift out the floor cover.

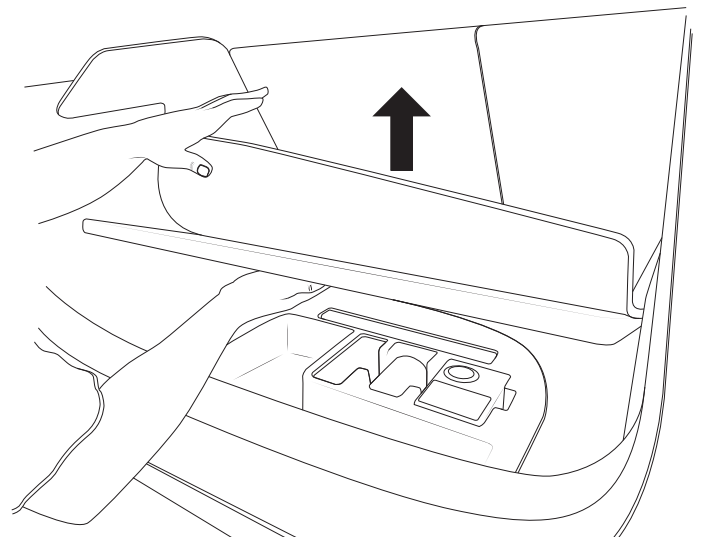

STEP 3

Unclip boot protective panel using a trim removal tool.

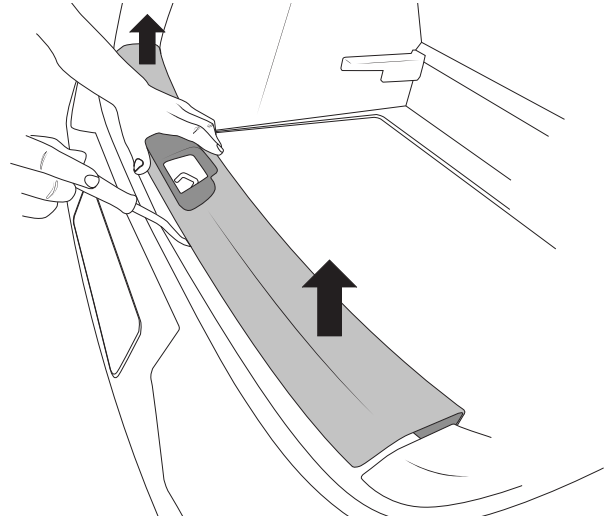

STEP 4

Pop out the left side panel using trim removal tool. You don't need to remove just out far enough to reach the wiring harness.

Repeat for right side of the vehicle.

Locate the harness plug. The following colours:

- Tail light** – Red
- Left turn signal** – Yellow
- Right turn signal** (on otherside of vehicle) – Yellow with trace
- Brake** – White
- Earth** – Body

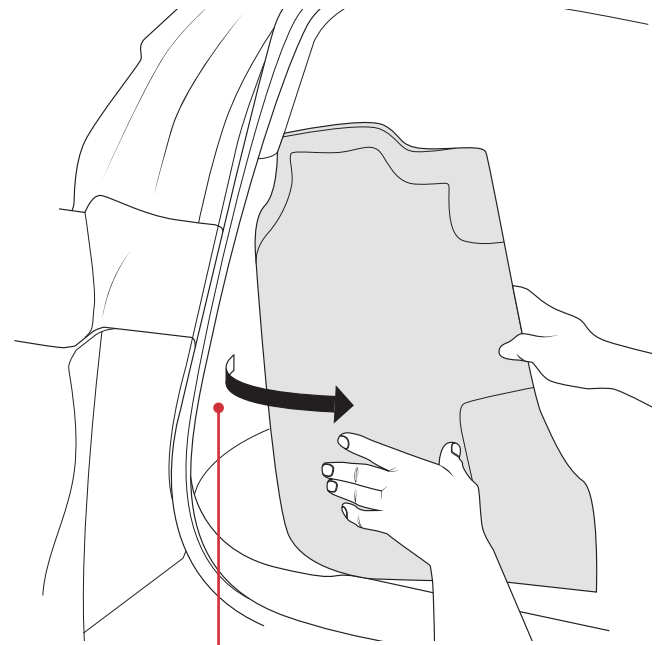
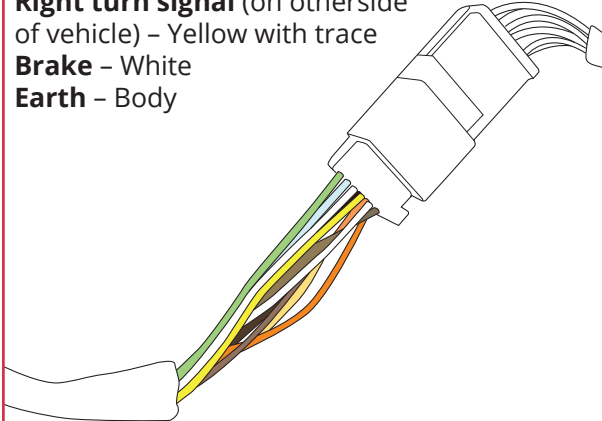

STEP 5

Strip wire and solder on Bypass Relay harness wire or use scotch lock connector.

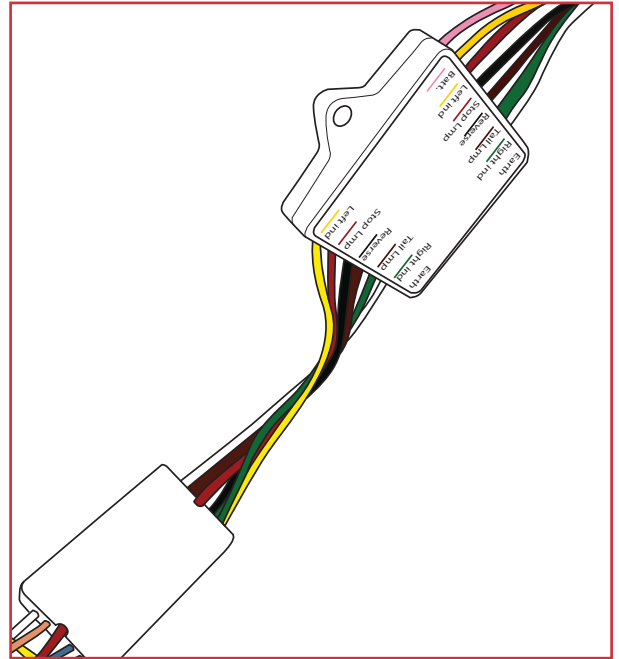
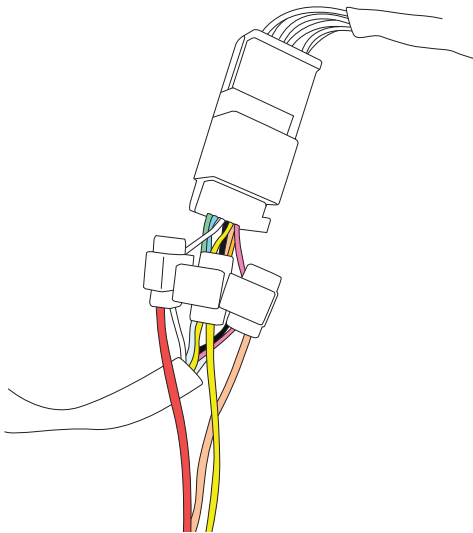

STEP 6

Drill a 12.5mm hole below height of the spare wheel tray.

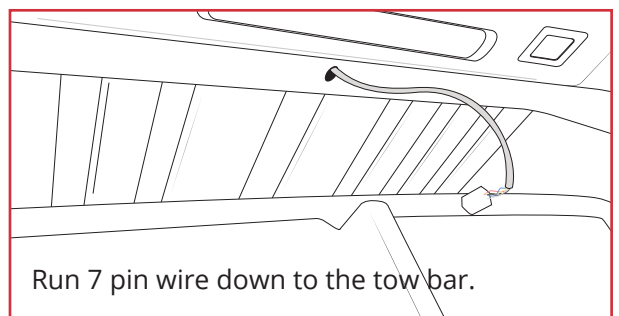
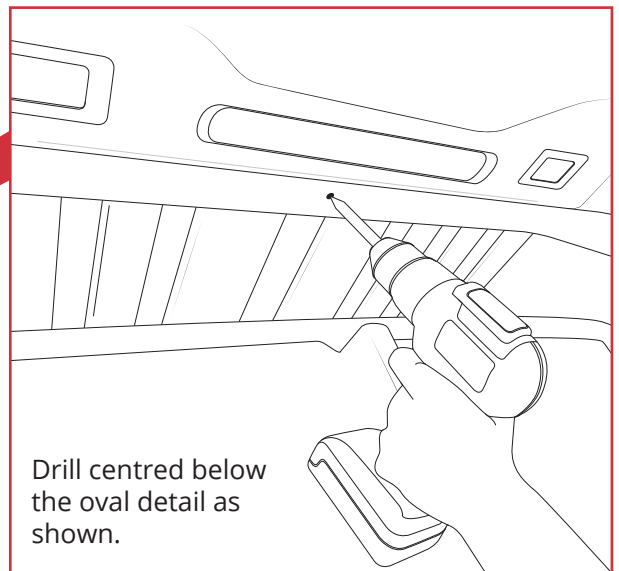
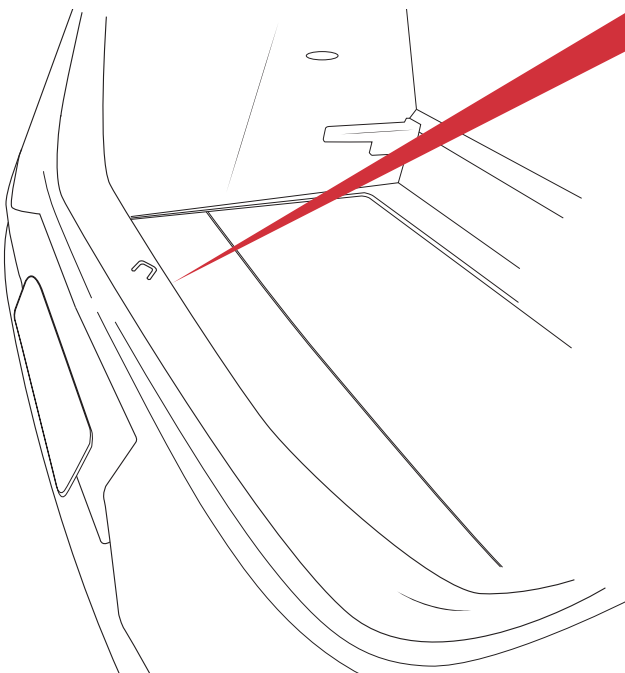

STEP 7

Fit ECU harness to vehicle and run the power wire down the passenger side of the vehicle next to the brake lines.

Connect to the positive terminal of the battery with a 10A fuse line.

Wire in 7 pin plug to ECU harness and test all functions on the vehicle are working correctly.

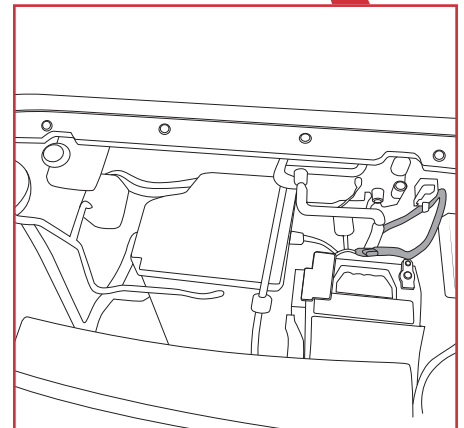
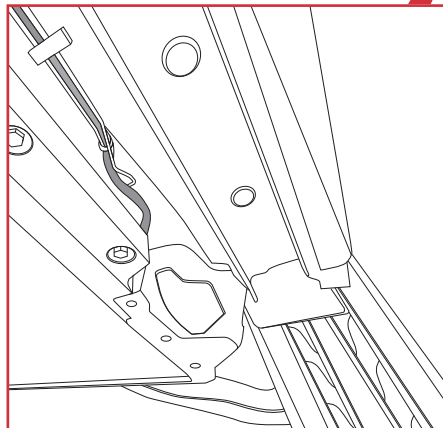
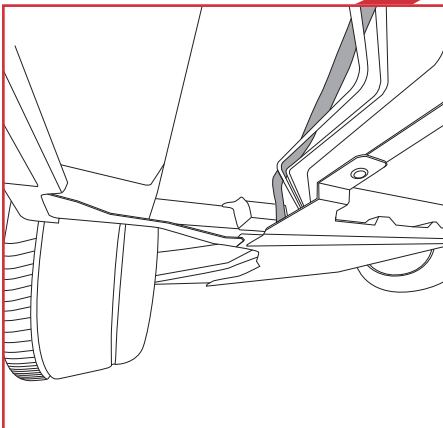
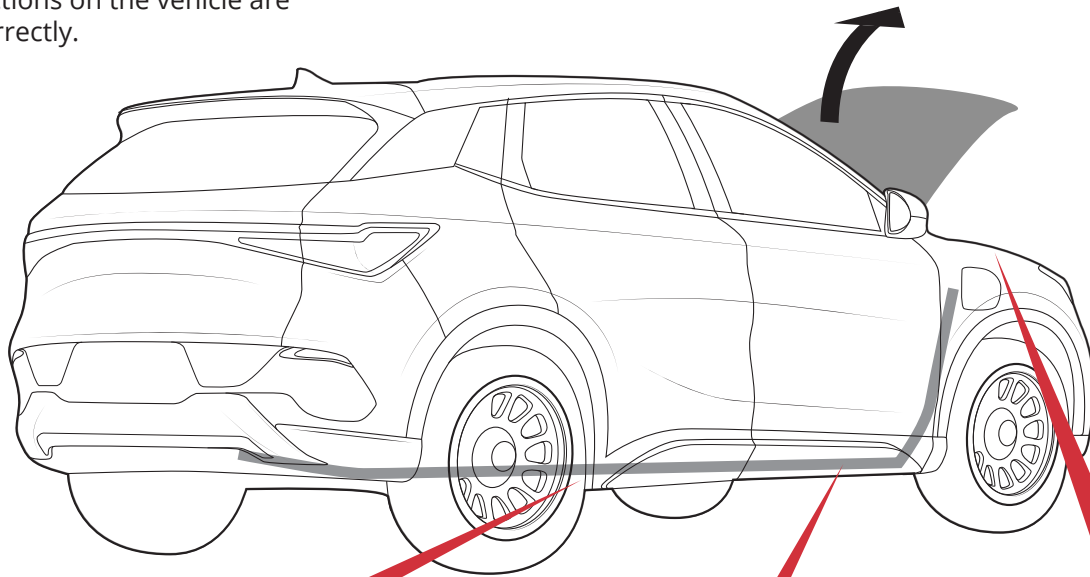

STEP 8

- A) Slide the towbar hitch into place.
- B) Use the pin to hold the hitch in place.
- C) Using an R clip, fix the pin in place.

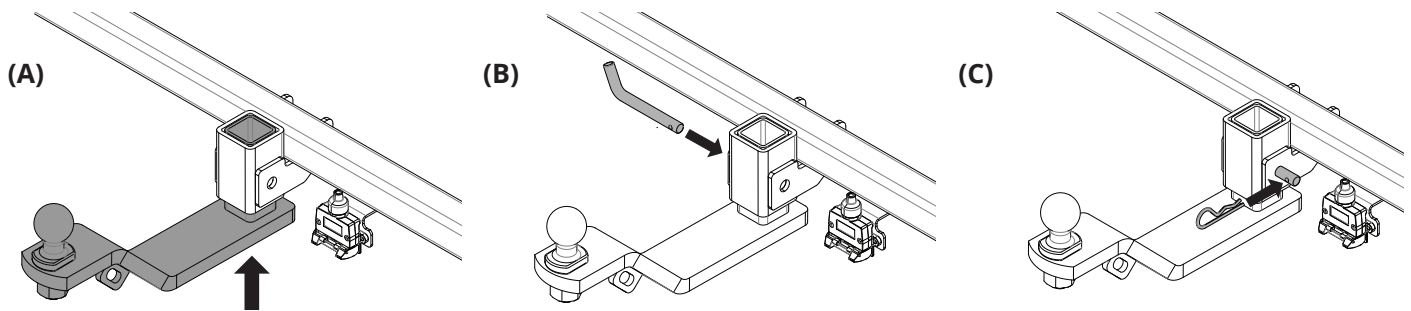

Installing bike rack adapter

- A) Slide the towbar hitch into place.
 - B) Use the pin to hold the hitch in place.
 - C) Using an R clip, fix the pin in place.
- Note anti-rattle bolt is positioned at the rear of the verticle hitch box.

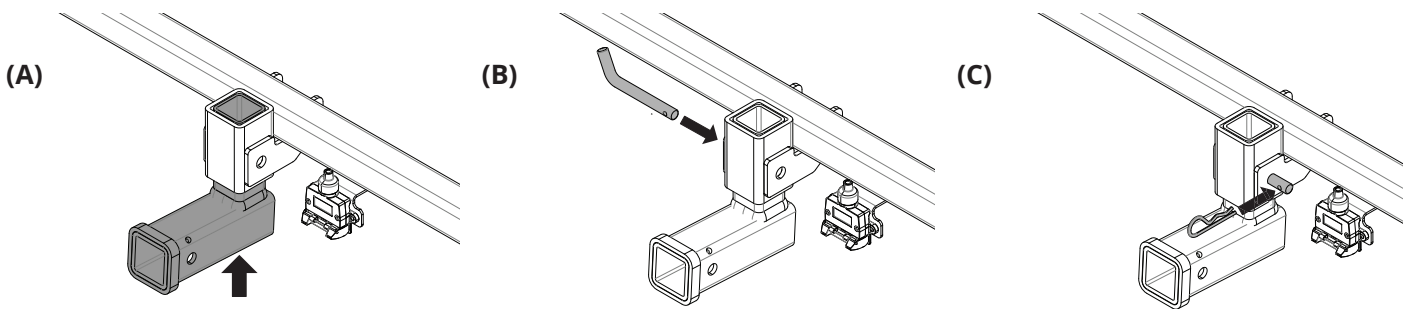

STEP 9

Install the load rating sticker provided, inside the drivers door.

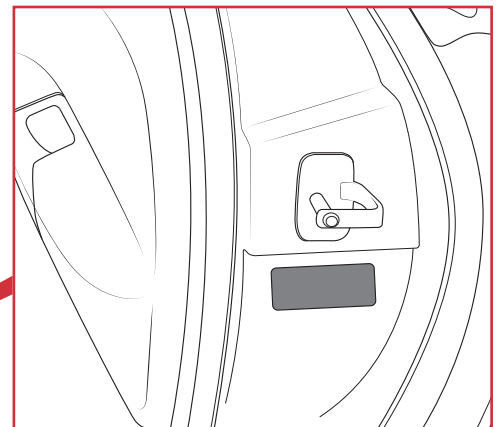
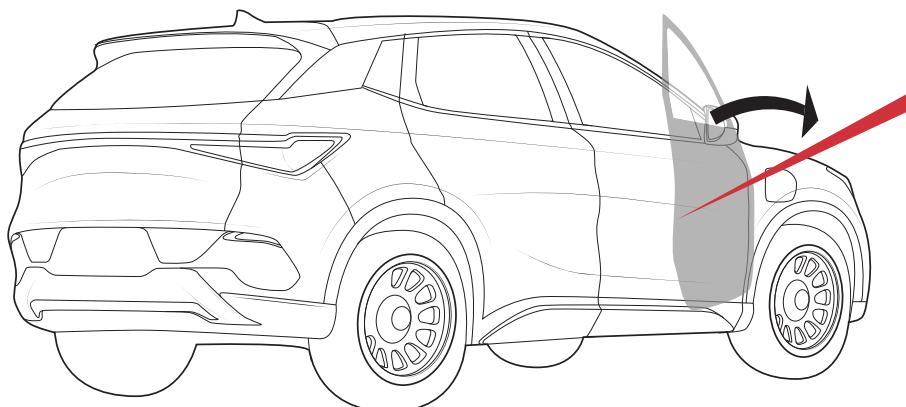

. EST 1956 .

CARASEL

TOWBARS

